



Quality Access Doors- FAST!

SUBMITTAL/TECHNICAL DATA SHEET

SKU: **BA-FD-8060**

FLOOR DOOR

NON HINGED, FLUSH DIAMOND PLATE

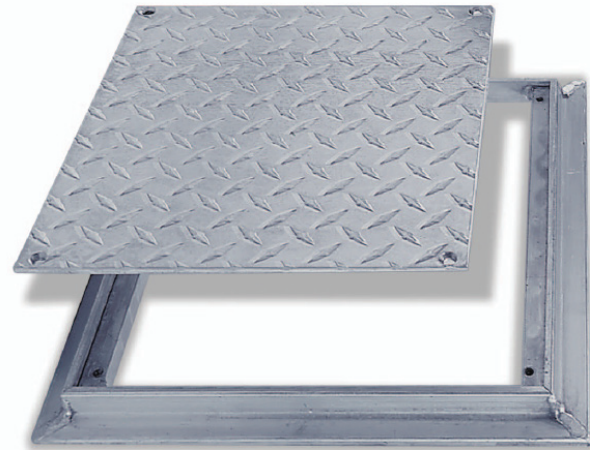

APPLICATION

Designed for interior and exterior applications that require an access opening that will blend in with the surrounding floor material

FEATURES

- Flush Diamond Plate door panel
- Door panel removable via screws

SPECIFICATIONS

MATERIAL: Aluminum

DOOR: 1/4" aluminum diamond plate reinforced for the live load of 150 lb/per sq. ft.

FRAME: 1" x 1" aluminum angle designed to be cast into concrete

STANDARD LATCH: Door panel is secured to frame with 1/4" x 1" flat head screws

FINISH: Mill finish

DIMENSIONS AND APPEARANCE

>> CLICK TO VIEW ADDITIONAL DETAILS AND PRICING <<

STANDARD SIZES:

DOOR SIZE W x H INCHES	(MM)	WEIGHT	
		LBS	KG
8 x 8	(203 x 203)	4	1.8
12 x 12	(305 x 305)	6	2.7
18 x 18	(457 x 457)	12	5.5
24 x 24	(610 x 610)	24	10.9

For detailed specifications see submittal sheet

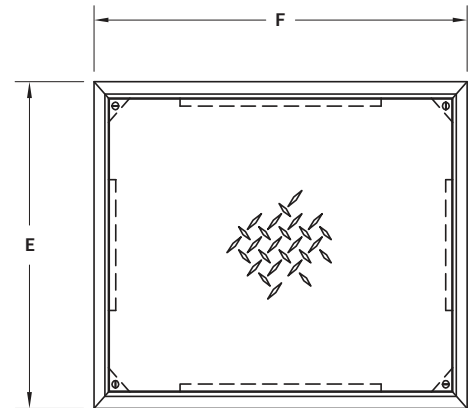

MANUFACTURED BY ACUDOR

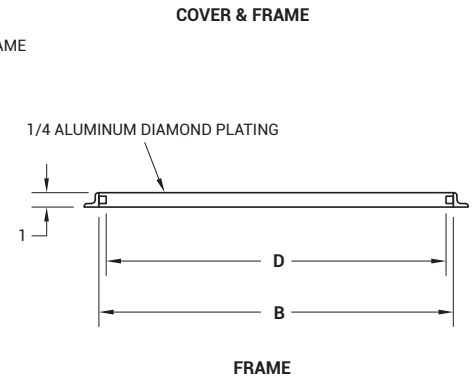
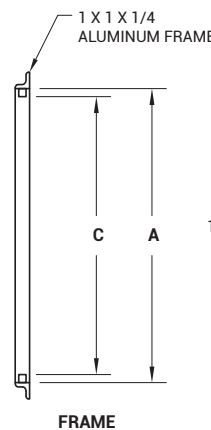
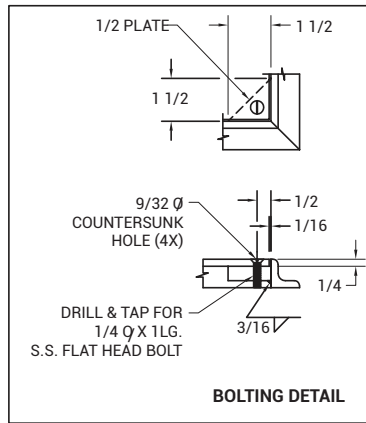

For a complete list of options visit www.BestAccessDoors.com

PROJECT DATA

Custom Sizes Available - Fast!

PROJECT NAME :	QTY	W	H	OPTIONS
ARCHITECT :				
DEALER :				
CONTRACTOR :				
LOCATION :	SPECIAL INSTRUCTIONS :			
DATE :				
TAGGING INSTRUCTIONS :	SUBMITTAL APPROVAL : (signature or stamp)			

Scan or Click



To view Pricing and Additional Product Info.

TELEPHONE:
1-800-483-0823
FAX:
1-888-828-6021



228 PARK AVE. S. #76520
NEW YORK, NY, 10003



WEBSITE:
www.BestAccessDoors.com
E-MAIL:
info@bestaccessdoors.com

BA-FD-8060 NON-HINGED, FLUSH DIAMOND PLATE FLOOR DOOR

NOMINAL DOOR SIZE	FRAME OPENING		CLEAR OPENING		OVERALL SIZE		WEIGHT
in. (mm)	A in. (mm)	B in. (mm)	C in. (mm)	D in. (mm)	E in. (mm)	F in. (mm)	LBS. (KG)
8 x 8	8 (203)	8 (203)	7 (178)	7 (178)	10 (254)	10 (254)	4 (2)
12 x 12	12 (305)	12 (305)	11 (279)	11 (279)	14 (356)	14 (356)	6 (3)
18 x 18	18 (457)	18 (457)	17 (432)	17 (432)	20 (508)	20 (508)	12 (6)
24 x 24	24 (610)	24 (610)	23 (584)	23 (584)	26 (660)	26 (660)	24 (11)

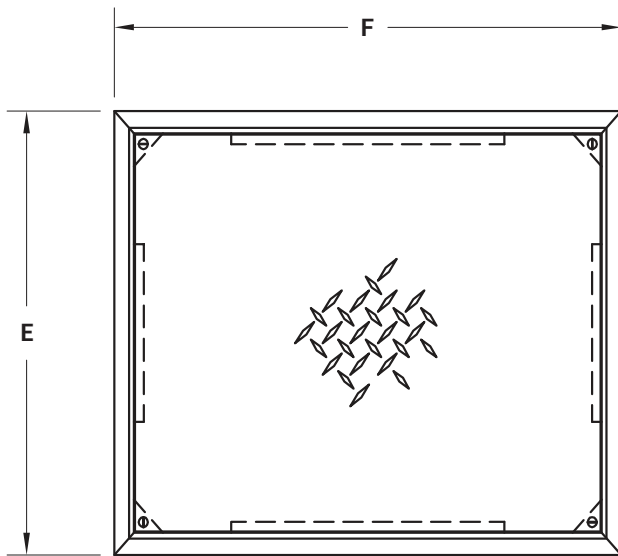

COVER & FRAME

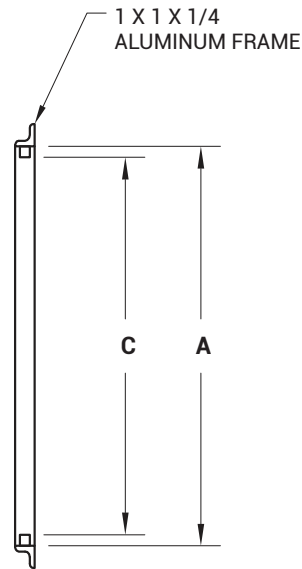

FRAME

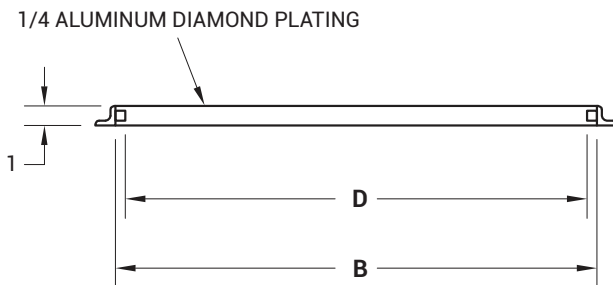

FRAME

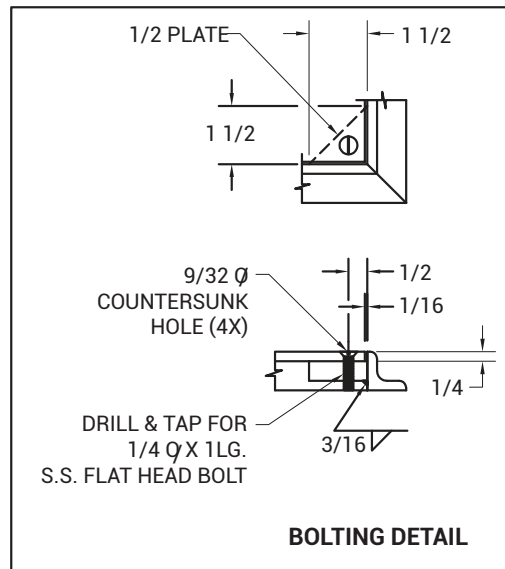

BOLTING DETAIL

- NOTES:
- MATERIAL: ALUMINUM
 - LOADING: 150 LBS. PER SQ. FT.
 - 316 STAINLESS STEEL NUTS & BOLTS