



Quality Access Doors- FAST!

SUBMITTAL/TECHNICAL DATA SHEET

SKU: BA-FRFD FLOOR DOOR

FIRE RATED, FLUSH DIAMOND PLATE

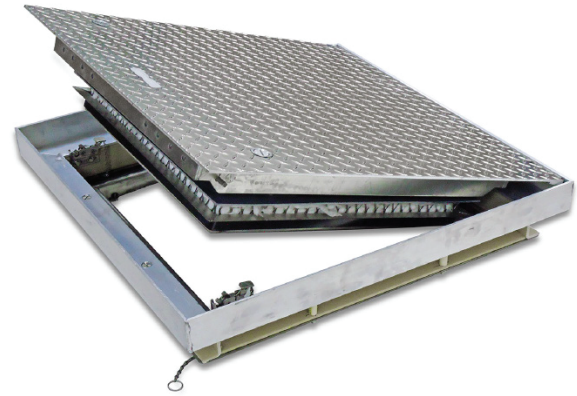

APPLICATION

- Maintains the fire rating of a 2 hour floor ceiling assembly
- Designed for interior applications

FEATURES

- Flush aluminum diamond plate cover
- Warnock Hersey International 2 hour fire rating
- Tested to NFPA 288 ; ASTM E 119

SPECIFICATIONS

MATERIAL: Aluminum door & top frame ; Stainless steel bottom frame, hinges & hardware

DOOR: 1/4" aluminum diamond plate reinforced for live load of 150 lb/per sq. ft.

FRAME: 3" x 3" x 1/4" aluminum top frame with thermal break 3 1/2" x 2" x 11 gauge stainless steel bottom frame

INSULATION: Two - 1" thick layers of ceramic blanket insulation attached to bottom frame

HINGE: Type 316 stainless steel continuous piano hinge

OPENING DEVICE: Door panel opens to 90 degrees. Automatic hold open arm with red vinyl grip keeps door in open position to ensure safe egress. Stainless steel compression springs provide lift assistance. U.L. listed 165 degrees fusible link is provided for automatic closing and latching in the event of smoke or fire.

LATCH: Stainless steel slam latch assembly with interior release

■ DIMENSIONS AND APPEARANCE

>> CLICK TO VIEW ADDITIONAL DETAILS AND PRICING <<

DOOR SIZE W x H INCHES (MM)	WEIGHT	
	LBS	KG
24 x 24 (610 x 610)	80	36
24 x 36 (610 x 914)	140	63
24 x 48 (610 x 1219)	160	73
30 x 30 (762 x 762)	130	59
30 x 36 (762 x 914)	160	73
36 x 36 (914 x 914)	190	86
36 x 48 (914 x 1219)	240	109
42 x 42 (1067 x 1067)	250	113
48 x 48 (1219 x 1219)	280	127

For detailed specifications see submittal sheet

MANUFACTURED BY ACUDOR

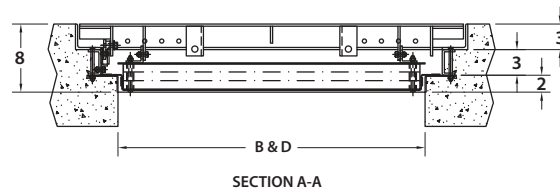

NOTES:

- MATERIAL: ALUMINUM & ST. STEEL
- LOADING: 150 LBS. PER SQ. FT.
- 316 STAINLESS STEEL NUTS & BOLTS
- CERTIFIED 2-HOUR FIRE RATING

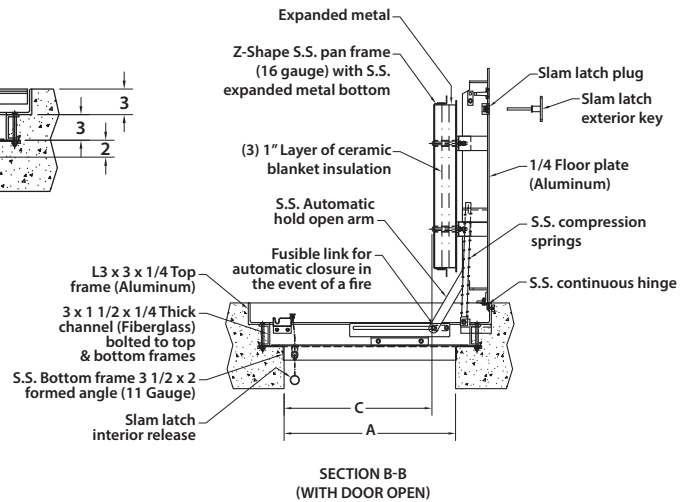
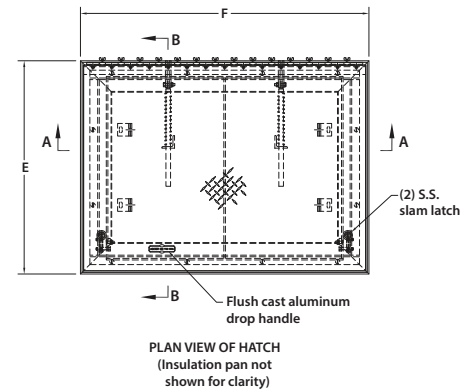

For a complete list of options visit www.BestAccessDoors.com

■ PROJECT DATA

Custom Sizes Available - Fast!

Scan or Click



PROJECT NAME :	QTY	W	H	OPTIONS
ARCHITECT :				
DEALER :				
CONTRACTOR :				
LOCATION :	SPECIAL INSTRUCTIONS :			
DATE :				
TAGGING INSTRUCTIONS :	SUBMITTAL APPROVAL : (signature or stamp)			

TELEPHONE:
1-800-483-0823
FAX:
1-888-828-6021



228 PARK AVE. S. #76520
NEW YORK, NY, 10003



WEBSITE:
www.BestAccessDoors.com
E-MAIL:
info@bestaccessdoors.com

To view Pricing and Additional Product Info.

BA-FRFD FIRE RATED FLOOR DOOR

NOMINAL DOOR SIZE	FRAME OPENING		CLEAR OPENING		OVERALL SIZE		WEIGHT
	in. (mm)	A in. (mm)	B in. (mm)	C in. (mm)	D in. (mm)	E in. (mm)	F in. (mm)
24 x 24 (610 x 610)	24 (610)	24 (610)	20 (508)	24 (610)	34 (864)	34 (864)	80 (36)
24 x 36 (610 x 914)	24 (610)	36 (914)	20 (508)	36 (914)	34 (864)	46 (1168)	140 (63)
24 x 48 (610 x 1219)	24 (610)	48 (1219)	20 (508)	48 (1219)	34 (864)	58 (1321)	160 (73)
30 x 30 (762 x 762)	30 (762)	30 (762)	26 (660)	30 (762)	40 (1016)	40 (1016)	130 (59)
30 x 36 (762 x 762)	30 (762)	36 (914)	26 (660)	36 (914)	40 (1016)	46 (1168)	160 (73)
36 x 36 (914 x 914)	36 (914)	36 (914)	32 (813)	36 (914)	46 (1168)	46 (1168)	190 (86)
36 x 48 (914 x 1219)	36 (914)	48 (1219)	32 (813)	48 (1219)	46 (1168)	58 (1473)	240 (109)
42 x 42 (1067 x 1067)	42 (1067)	42 (1067)	38 (965)	42 (1067)	52 (1321)	52 (1321)	250 (113)
48 x 48 (1219 x 1219)	48 (1219)	48 (1219)	44 (1118)	48 (1219)	58 (1473)	58 (1473)	280 (127)

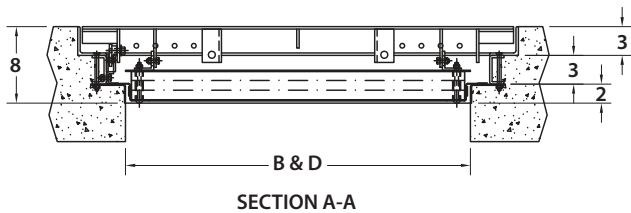
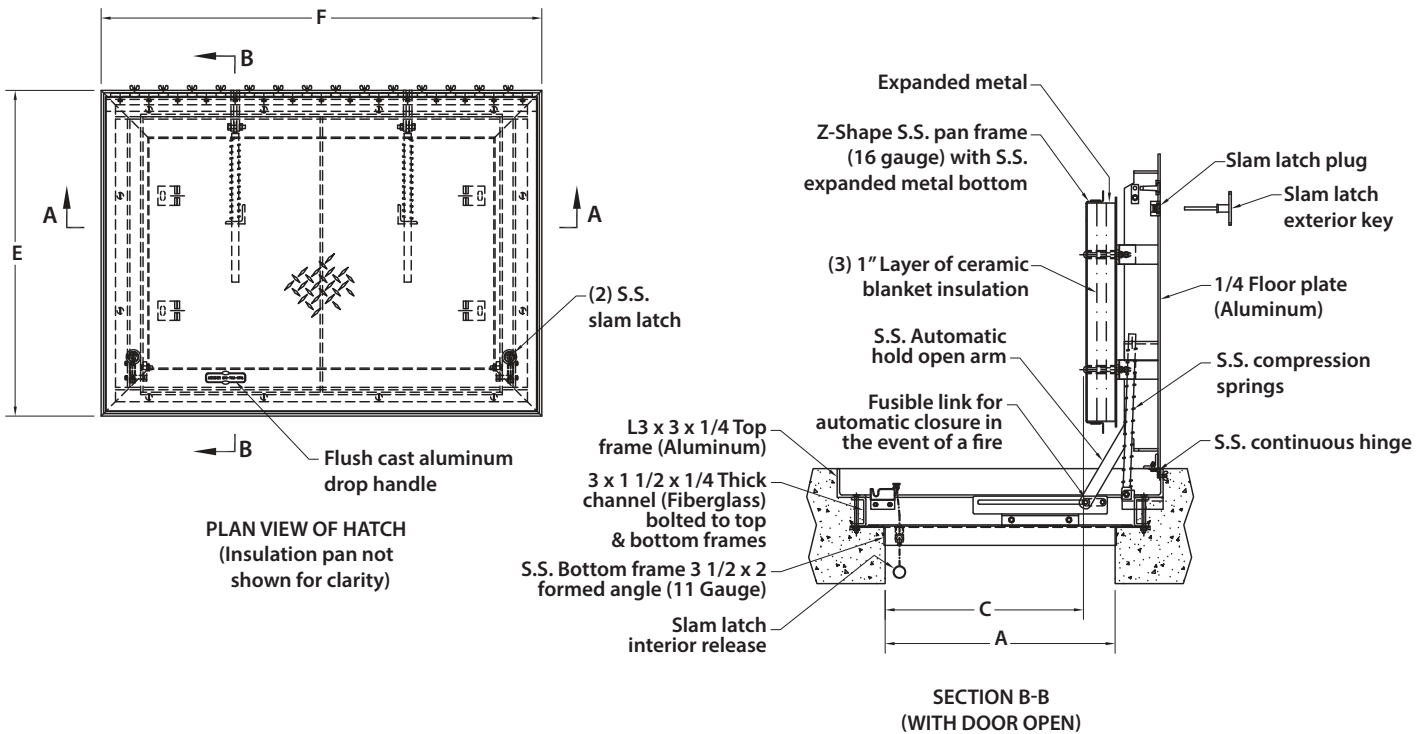

- NOTES:
- MATERIAL: ALUMINUM & ST. STEEL
 - LOADING: 150 LBS. PER SQ. FT.
 - 316 STAINLESS STEEL NUTS & BOLTS
 - CERTIFIED 2-HOUR FIRE RATING