

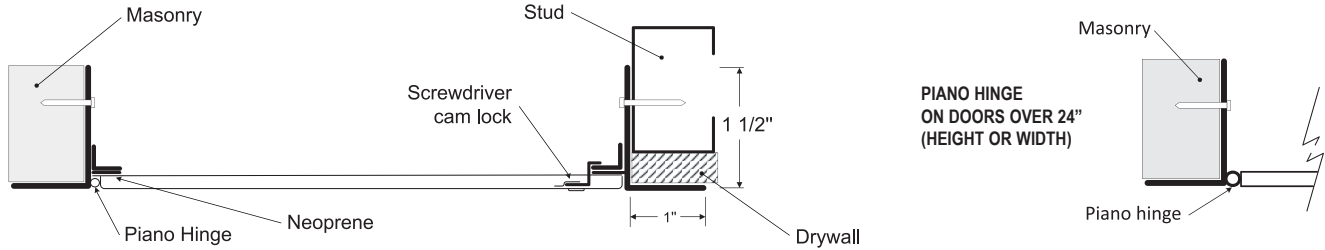

GENERAL PURPOSE ACCESS DOOR WITH NEOPRENE GASKET FOR ALL SURFACE TYPES

BA-AHD-60 NEOPRENE

INSTALLATION



DIMENSIONS AND APPEARANCE

LEED ready: This product contributes to LEED® credits.

Your odd sizes:
Made in 5 days

DOOR SIZE W x H inches (MM)	NUMBER OF LOCKS	WEIGHT LBS	KG
6 x 6 (152 x 152)	1	2	0.9
8 x 8 (203 x 203)	1	3	1.4
8 x 12 (203 x 304)	1	4	1.8
10 x 10 (254 x 254)	1	4	1.8
12 x 12 (304 x 304)	1	5	2.3
12 x 16 (304 x 406)	1	6.2	2.8
12 x 18 (304 x 457)	1	7	3.2
12 x 24 (304 x 609)	1	8	3.6
14 x 14 (356 x 356)	1	7	3.2
16 x 16 (406 x 406)	1	8	3.6
18 x 18 (457 x 457)	1	9	4.1
18 x 24 (457 x 609)	1	13	5.9
20 x 20 (508 x 508)	1	11	5.
22 x 22 (558 x 558)	1	13	5.9
* 22 x 30 (558 x 762)	2	17	7.7
* 22 x 36 (558 x 914)	2	19	8.6
* 24 x 24 (609 x 609)	1	15	6.8
* 24 x 30 (609 x 762)	2	20	9.1
* 24 x 36 (609 x 914)	2	22	10
* 24 x 48 (609 x 1219)	2	28	12.7
* 30 x 30 (762 x 762)	4	23	12.7
* 36 x 36 (914 x 914)	4	31	14.1

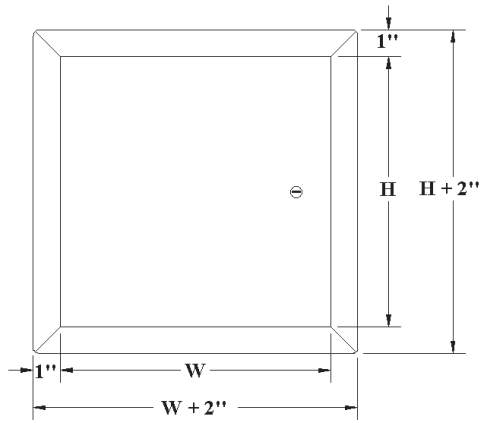

Rough wall opening is door size + 1/4" or + 6mm
*Piano hinge on doors over 24 inches (height or width) - The LHD model is recommended for over 1296 sq. inches

DESCRIPTION AND MATERIAL SPECIFICATION

- Material:** 16 gauge cold rolled steel
- Hinge:** continuous piano type hinge
- Lock / latch:** screwdriver operated cam latch
- Finish:** high quality white powder coat primer
- Packaging:** individually wrapped, 1 per box
- Gasketing:** neoprene gasket

POPULAR OPTIONS
Lock / latch: key operated cylinder cam latch, hex head cam latch, pinned hex head cam latch, handle operated cam latch, mortise preparation for cylinder.

Material: stainless steel 304 #4 (brushed finish)

Click here to view the Products



PROJECT DATA

PROJECT NAME:	QTY	W	H	OPTIONS
ARCHITECT:				
DEALER:				
CONTRACTOR:				
LOCATION:	SPECIAL INSTRUCTIONS:			
DATE:				
TAGGING INSTRUCTIONS:	SUBMITTAL APPROVAL: (signature or stamp)			

ADDRESS: 427 N Tatnail St, #76520 Wilmington, DE 19802-2230

Tel.: 1-800-483-0823
Fax: 1-888-828-6021

www.bestaccessdoors.com
sales@bestaccessdoors.com