



Quality Access Doors- FAST!

SUBMITTAL/TECHNICAL DATA SHEET

DESCRIPTION

Insulated Lightweight Access Door offers a solution to larger openings in vertical or horizontal applications. Available in both pre-finished, embossed, galvanized steel, and aluminum door skins.

FEATURES

- Lightweight
- Ceiling Application
- Custom Sizing

SPECIFICATIONS

MODEL: BLW/BLW-D

DOOR: 26 gauge Steel, Pre-Finished, Embossed

FRAME: .045 inch 6063-T5 Extruded Aluminum

SIZE: Min:

- Single Door: 12 inches by 12 inches
 - Double Door: 24 inches by 24 inches
- Max:
- Single Skin: 18 inches by 72 inches, 24 inches by 60 inches or 48 inches by 48 inches
 - Double Door: 60 inches by 96 inches, 66 inches by 90 inches or 84 inches by 84 inches

INSTALLATION: Ceiling

FLANGE: 1-5/16 inch, Rolled

HINGE: Continuous Piano

FINISH:
Door Skin: White Embossed Steel
Frame: Clear Anodized Aluminum

OPTIONS: Latches, Door Styles and Gaskets

WARRANTY: 1 year

For a complete list of options visit www.BestAccessDoors.com

SKU: **BA-BLW**

LIGHTWEIGHT ACCESS DOOR



DIMENSIONS AND APPEARANCE

>> [CLICK TO VIEW ADDITIONAL DETAILS AND PRICING <<](#)

ORDER GUIDE:

BASE	FLANGE	WIDTH	X	LENGTH	OPTIONS
BLW		STANDARD SIZES (W X L)			
	L Key Operated Cam Latch	12" X 12"	24" X 48"		A Aluminum Insert Panel
		18" X 18"	30" X 30"		
		22" X 30"	30" X 36"		G Gasketing
	T Screwdriver Cam Latch	22" X 36"	36" X 36"		
		24" X 24"	48" X 48"*		D Double Door
		24" X 36"	60" X 48"*		
			72" X 48"*		

Rough opening is door size + 1/4 inch minimum.
Additional sizes available, call for more information.
*Double Door Construction.

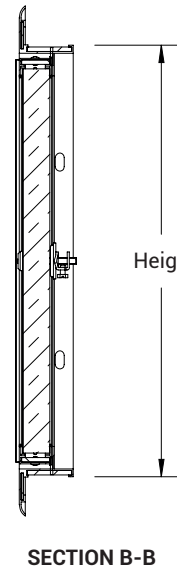
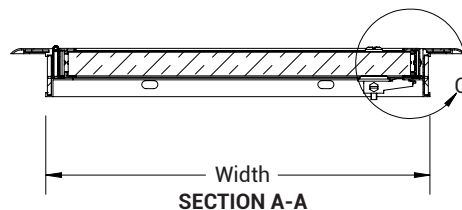
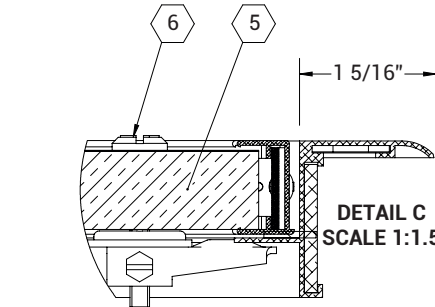
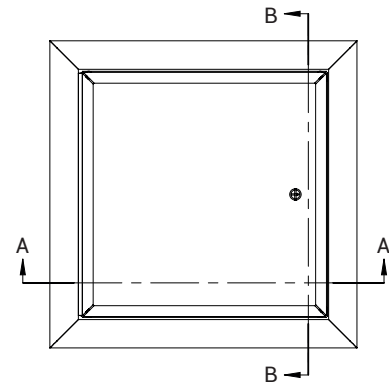

For Detailed Specifications See Submittal Sheet

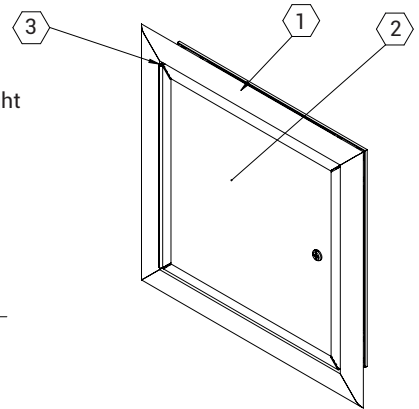

PROJECT DATA

Custom Sizes Available - Fast!

Scan or Click



To view Pricing and Additional Product Info.

PROJECT NAME :	QTY	W	H	OPTIONS
ARCHITECT :				
DEALER :				
CONTRACTOR :				
LOCATION :	SPECIAL INSTRUCTIONS :			
DATE :				
TAGGING INSTRUCTIONS :	SUBMITTAL APPROVAL : (signature or stamp)			

TELEPHONE:
1-800-483-0823
FAX:
1-888-828-6021



228 PARK AVE. S. #76520
NEW YORK, NY, 10003



WEBSITE:
www.BestAccessDoors.com
E-MAIL:
info@bestaccessdoors.com

BA-BLW LIGHTWEIGHT ACCESS DOOR

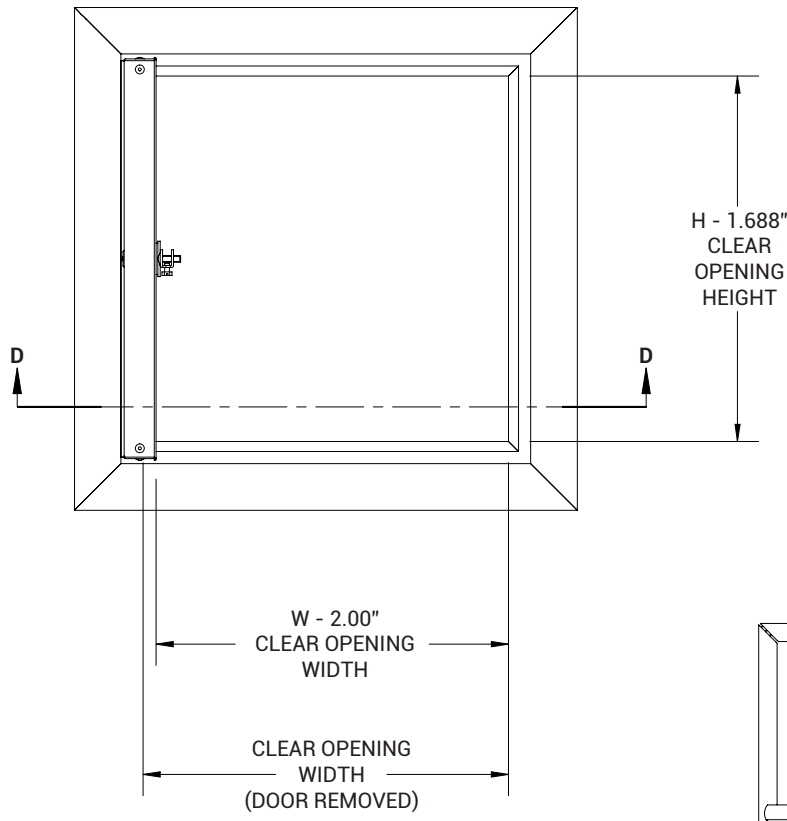

NOTES:

- ① FRAME: .080-6063-T5 Extruded Aluminum
- ② DOOR: FRAME: .045-6063-T5 Extruded Aluminum
PANEL: 24 Ga Galv Steel
- ③ HINGE:
- ④ FINISH: FRAME: Clear Anodized
PANEL: Pre-Finished White Embossed
- ⑤ INSULATION: 3/4" Extruded Polystyrene, 3.8 R Value
- ⑥ LATCH: Screwdriver Cam

OPTIONS:

- Gasket Installed (G)
- Aluminum Door Panel, Mill (A)

ROUGH OPENING: $W + 0.25'' \times H + 0.25''$
CLEAR OPENING: $W - 2.00'' \times H - 1.688''$
DEGREE OF OPENING: 180°

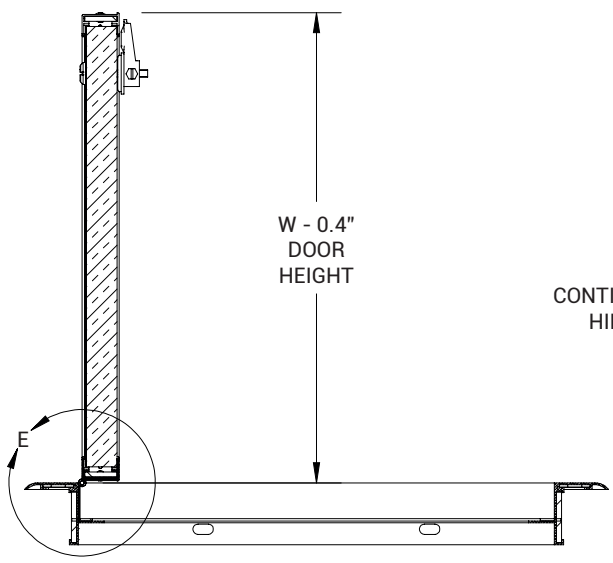
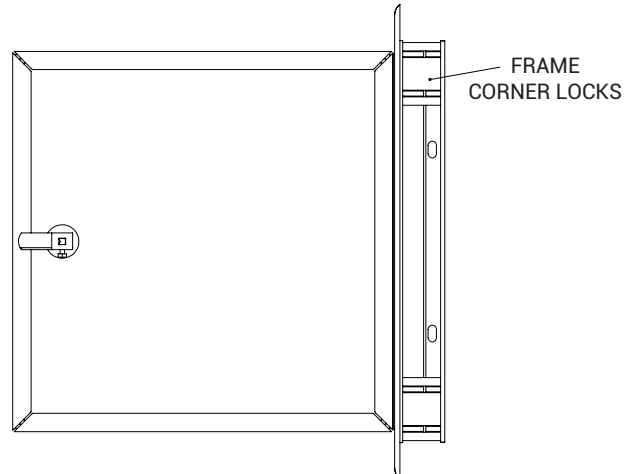

SECTION D-D

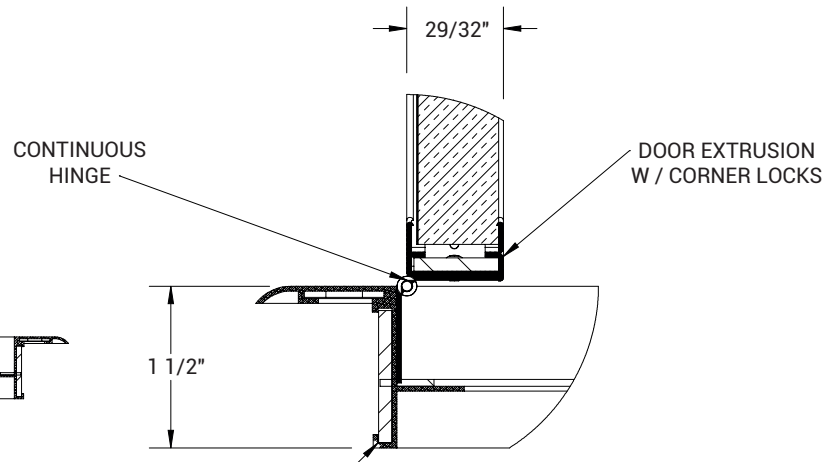

DETAIL E
SCALE 1 : 2