



Quality Access Doors- FAST!

SUBMITTAL/TECHNICAL DATA SHEET

DESCRIPTION

Block the intrusion of exterior environmental noise while providing safety and security with the industry's best OITC 47-STC 50 automatic Acoustical Smoke Vent.

FEATURES

- STC 50 - OITC 47
- ISO 140-18 sound rating 36.7 dB
- Superior Sound Control
- Pre-Finished Black Interior

SPECIFICATIONS

DOOR: Double Leaf

SOUND RATING: Sound Transmission Class (STC) 50, Outdoor-Indoor Transmission Class (OITC) 47, ISO 140-18 sound rating 36.7dB

MATERIAL: 12 gauge galvalume steel.

FINISH: Inside: Powder Coat, Black Outside - Powder Coat, High Reflectance White

COVER: Metal with liner, withstands a live load of 40psf

CURB: Double wall curb with easy tab counterflash and mounting flange.

INSULATION: Mineral wool with sound mat in cover and curb; total R-16.8.

HARDWARE: Stainless steel heavy-duty pintle hinge. Gas spring with damper open cover against 10psf load. Zinc plated hold open arm.

LATCH: Zinc plated steel rotary latch designed to hold covers closed against 90psf wind uplift.

CERTIFICATION: UL 793 listed, Optional FM 4330 approved.

MINIMUM SIZE: 48 inches by 96 inches.

MAXIMUM SIZE: 72 inches by 192 inches.

WARRANTY: 5 year

For a complete list of options visit www.BestAccessDoors.com

SKU: BA-BSVZG-Q

QUAD DOOR ACOUSTIC

MAX™ Y



DIMENSIONS AND APPEARANCE

>> CLICK TO VIEW ADDITIONAL DETAILS AND PRICING <<

ORDER GUIDE:

BASE	WIDTH	X	LENGTH	DOOR	CURB	OPENING	LINK TEMP	CLOSING	OPTIONS
BSVZG				Q				R	-
	STANDARD SIZES (IN.)			Q - Quad Door	2 - DOUBLE WALL 3 - CURB MOUNT	N - NO ELECTRICAL L - 24VDC/24VAC H - 110VAC/240VAC A - LINEAR ACTUATOR	165 212 280 350 360 450	R - ROOFTOP CLOSE W - MANUAL WINCH L - LINEAR ACTUATOR	SMF - FM LABELED OP1 - DOOR POSITION SENSOR B_ - BURGLAR BARS

Additional sizes and options available, call for more information.

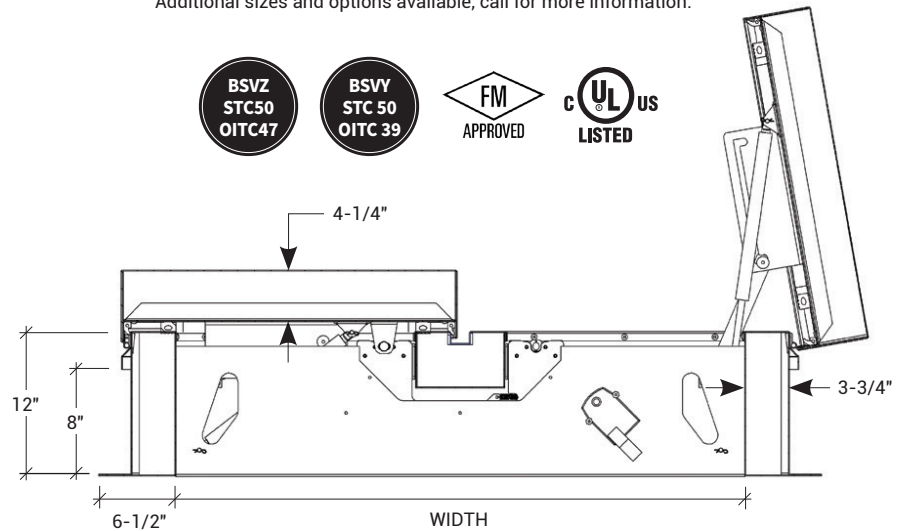

PROJECT DATA

Custom Sizes Available - Fast!

Scan or Click



PROJECT NAME :	QTY	W	H	OPTIONS
ARCHITECT :				
DEALER :				
CONTRACTOR :				
LOCATION :	SPECIAL INSTRUCTIONS :			
DATE :	SUBMITTAL APPROVAL : (signature or stamp)			
TAGGING INSTRUCTIONS :				

TELEPHONE:
1-800-483-0823
FAX:
1-888-828-6021



228 PARK AVE. S. #76520
NEW YORK, NY, 10003



WEBSITE:
www.BestAccessDoors.com
E-MAIL:
info@bestaccessdoors.com

To view Pricing and Additional Product Info.