



Quality Access Doors- FAST!

SUBMITTAL/TECHNICAL DATA SHEET

DESCRIPTION

Our Coastal Zone Exterior Access Door is the industry's only high velocity and impact tested door.

With a design pressure of +/- 80psf, this door is sure to withstand mother nature's toughest storms.

APPLICATION

- Impact, Air + Wind Pressure Tested
- Insulated for Temperature Control
- Custom Sizes

FEATURES

ROUGH OPENING: 24 3/8" wide x 36 3/8" high

DOOR: 24 gauge Steel

FRAME: .080 inch 6063-T5 Extruded Aluminum

FLANGE: 1 inch Exposed Flange

HINGE: Stainless Steel Continuous Piano

INSTALLATION: Wall

FINISH: Paint Grip Door and Mill Flange

INSULATION: 2 inch Polyurethane; R-11

GASKETING: EPDM Self-Adhesive, Continuous

COMPLIANCE: Florida Product Approval # FL22309

WARRANTY: 1 year

For a complete list of options visit www.BestAccessDoors.com



SKU: **BA-BXTA-H**
COASTAL ZONE
EXTERIOR ACCESS DOOR
 WITH NON-LOCKING HANDLE

DIMENSIONS AND APPEARANCE

>> [CLICK TO VIEW ADDITIONAL DETAILS AND PRICING <<](#)

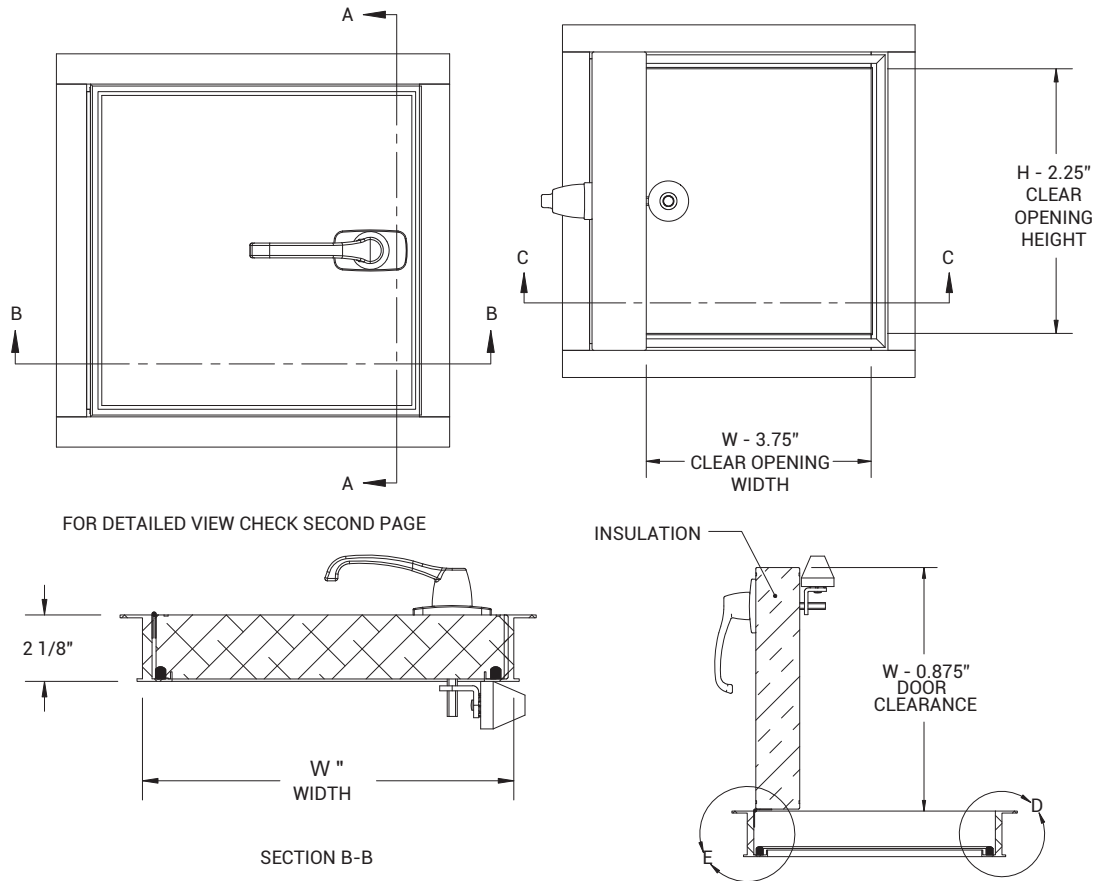

PROJECT DATA

Custom Sizes Available - Fast!

PROJECT NAME :	QTY	W	H	OPTIONS
ARCHITECT :				
DEALER :				
CONTRACTOR :				
LOCATION :	SPECIAL INSTRUCTIONS :			
DATE :	SUBMITTAL APPROVAL : (signature or stamp)			
TAGGING INSTRUCTIONS :				

Scan or Click



To view Pricing and Additional Product Info.

TELEPHONE:
1-800-483-0823
FAX:
1-888-828-6021



228 PARK AVE. S. #76520
NEW YORK, NY, 10003



WEBSITE:
www.BestAccessDoors.com
E-MAIL:
info@bestaccessdoors.com

BA-BXTA-H

COASTAL ZONE EXTERIOR ACCESS DOOR WITH NON-LOCKING HANDLE

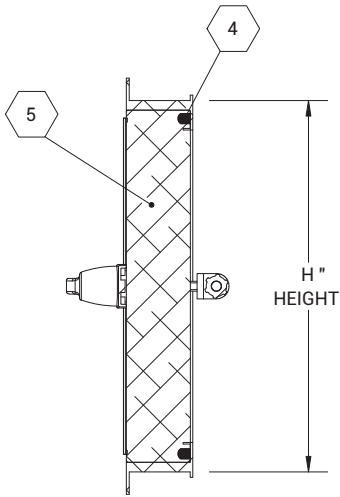

SECTION A-A

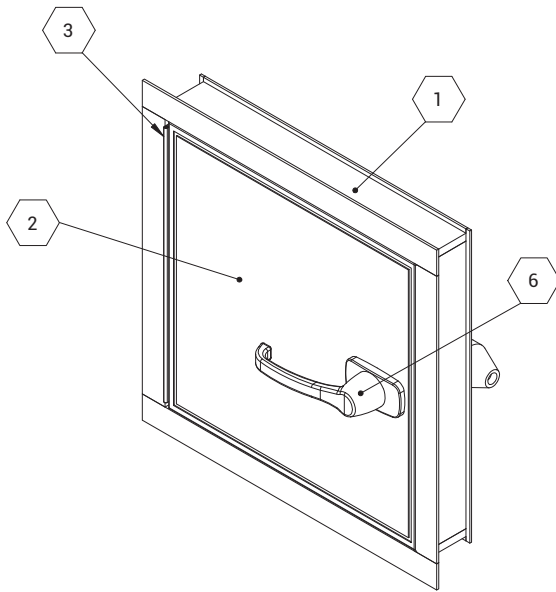

NOTES:

- ① FRAME: 6063-T5 Ext Aluminum, Mill Finish
- ② DOOR:
- ③ HINGE: Continuous Stainless Steel Hinge
- ④ GASKET: EPDM Self-Adhesive, Continuous Four Sides
- ⑤ INSULATION: Foam Insulation, 2-1/4lb Density, 12 R-Value
- ⑥ LATCH: Non-Locking Handle
- ⑦ LOCK: No Lock

OPTIONS:

DRIP CAP (C)

ROUGH OPENING: W" X H"
CLEAR OPENING: W - 3.75" X H - 2.25"
DEGREE OF OPENING: 180
LATCHING POINTS: VARIES

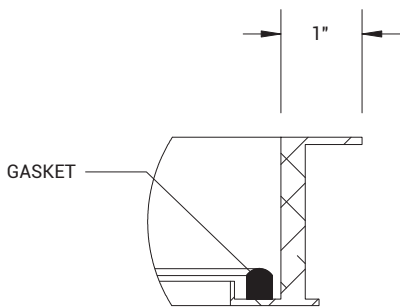
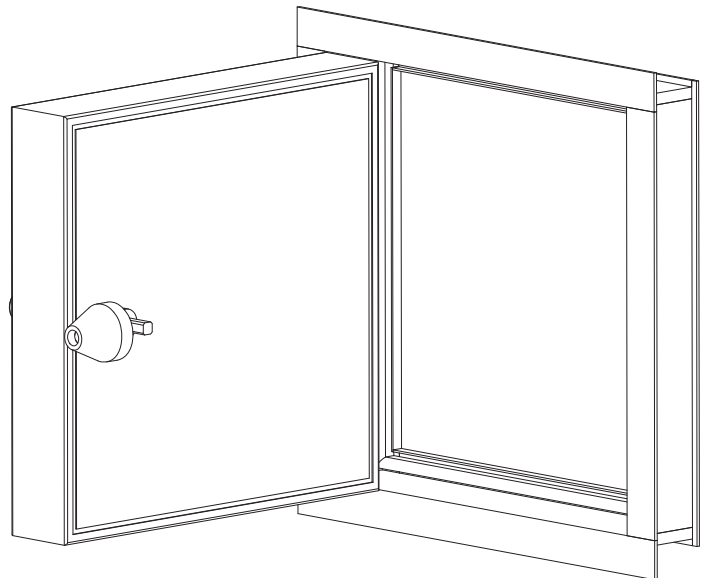
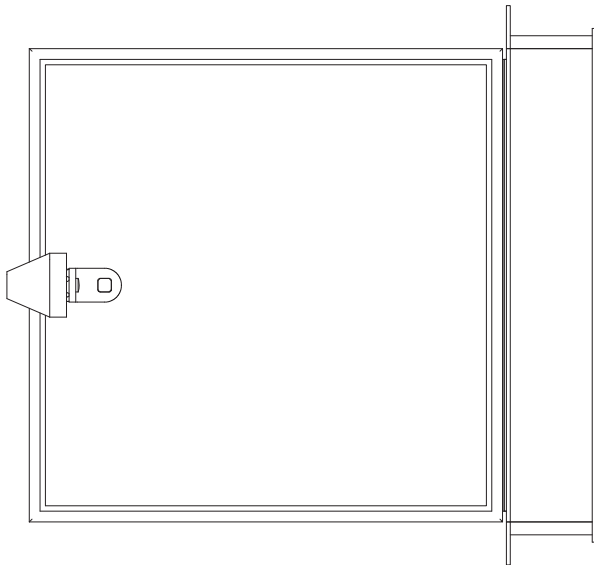

DETAIL D
SCALE 1 : 3

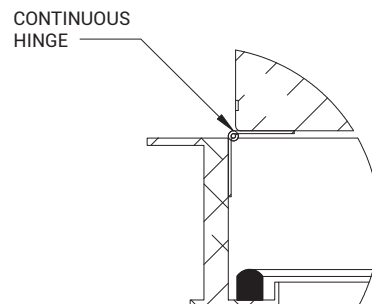

DETAIL E
SCALE 1 : 3