



Quality Access Doors - FAST!

SUBMITTAL/TECHNICAL DATA SHEET

Door is fabricated from 16 gauge, galvanized steel with a prime coat finish and 1" thick rigid foam insulation.

Frame is fabricated from 16 gauge, galvanized steel with a prime coat finish and provided with bolt holes.

Hinge is concealed and operates completely out of sight, so that only the door and frame are visible.

Exterior latch features a threaded ring latch or key operation.

Interior latch Release is included enabling the door to be opened from the inside.

Finish is a prime coat white, suitable for painting.



SKU: **BA-EDI**

EXTERIOR DOOR

FOR WALLS AND CEILINGS

GUIDE SPECIFICATION

Exterior Access Doors (specify model number and options). Access door frame shall be fabricated from 16 gauge galvanized steel with a prime coat white finish and provided with bolt holes. Access door panel shall be fabricated from 16 gauge galvanized steel with a prime coat white finish. Door shall be filled with 1" thick, rigid foam insulation and neoprene gasket on four sides. Access door shall have a concealed hinge with exterior lock that features a threaded ring latch or key operation. Internal latch release is included enabling the door to be opened from the inside. Finish shall be prime coat white suitable for painting.

MODEL NUMBER AND OPTIONS SELECTION

BASE MODEL NUMBER

- EDI Exterior Door for Walls and Ceilings With Internal Release Latch

SUFFIX OPTIONS

- GB Galvanized Drywall Bead
- SS Stainless Steel Construction (Type 304 No. 4 Satin Finish)

For a complete list of options visit www.BestAccessDoors.com

DIMENSIONS AND APPEARANCE

>> CLICK TO VIEW ADDITIONAL DETAILS AND PRICING <<

STANDARD SIZES:

NOMINAL DOOR SIZE (W x H)	WALL OPENING (minimum required)	LOCK QTY	WEIGHT LBS
EDI 8" x 8"	8-3/8" x 8-3/8"	1	5.0 LBS.
EDI 12" x 12"	12-3/8" x 12-3/8"	1	15.0 LBS.
EDI 14" x 14"	14-3/8" x 14-3/8"	1	17.0 LBS.
EDI 18" x 18"	18-3/8" x 18-3/8"	1	20.0 LBS.
EDI 22" x 30"	22-3/8" x 30-3/8"	2	32.0 LBS.
EDI 24" x 24"	24-3/8" x 24-3/8"	1	28.0 LBS.
EDI 24" x 36"	24-3/8" x 36-3/8"	2	40.0 LBS.
EDI 30" x 30"	30-3/8" x 30-3/8"	2	38.0 LBS.
EDI 36" x 36"	36-3/8" x 36-3/8"	2	50.0 LBS.
EDI 36" x 48"	36-3/8" x 48-3/8"	2	81.0 LBS.

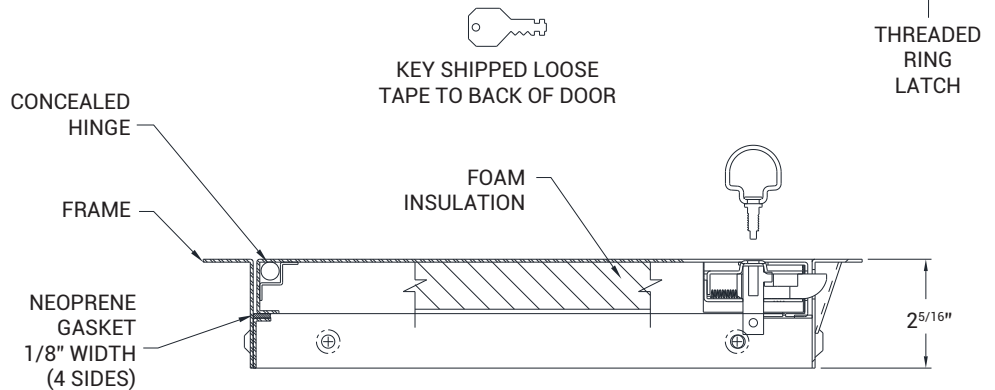
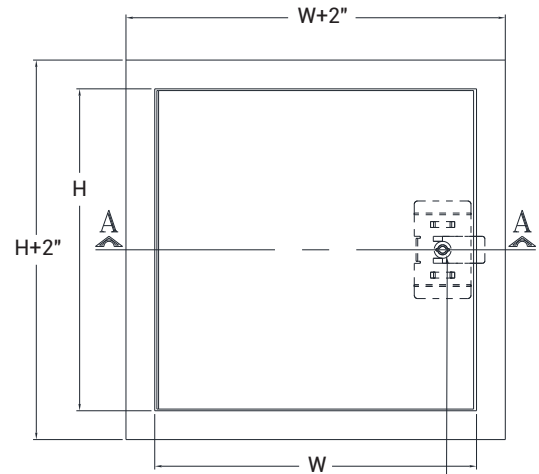

PROJECT DATA

Custom Sizes Available - Fast!

Scan or Click



To view Pricing and Additional Product Info.

PROJECT NAME :	QTY	W	H	OPTIONS
ARCHITECT :				
DEALER :				
CONTRACTOR :				
LOCATION :	SPECIAL INSTRUCTIONS :			
DATE :	SUBMITTAL APPROVAL : (signature or stamp)			
TAGGING INSTRUCTIONS :				

TELEPHONE:
1-800-483-0823
FAX:
1-888-828-6021



228 PARK AVE. S. #76520
NEW YORK, NY, 10003



WEBSITE:
www.BestAccessDoors.com
E-MAIL:
info@bestaccessdoors.com