



# Best Access Doors

## Best Access Doors

Phone: 1-800-483-0823  
 Fax: 1-888-828-6021  
 Email: sales@bestaccessdoors.com  
 Website: www.bestaccessdoors.com

## SYSTEM BA-F2 - 5/8"

OPEN HINGE, REMOVABLE DOOR FOR 5/8" DRYWALL DESIGNED FOR NON-RATED WALLS AND CEILINGS.

[Click here to view the Products](#)

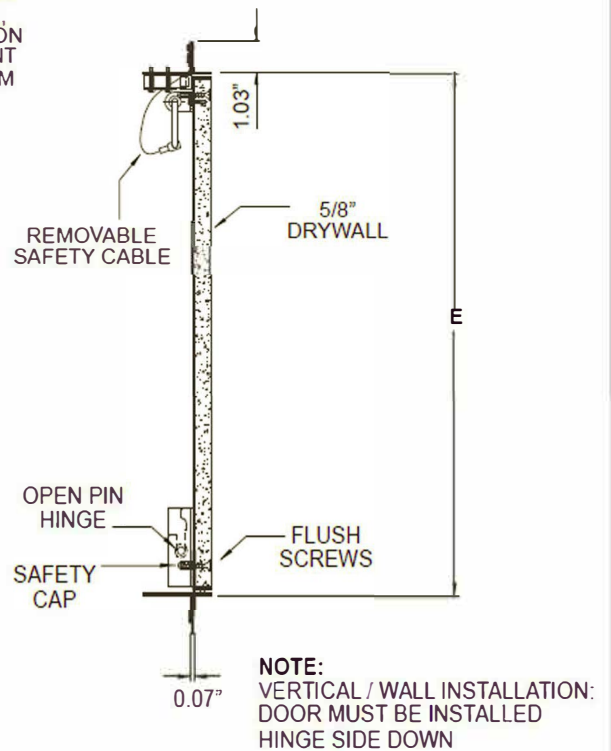
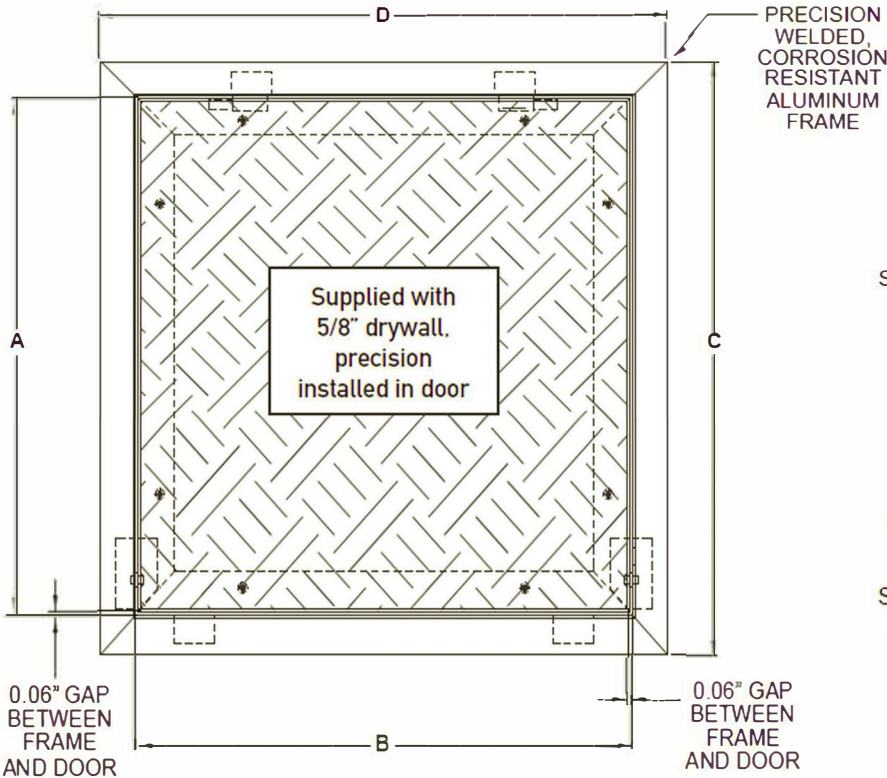
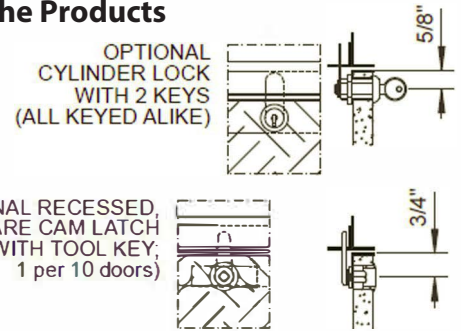
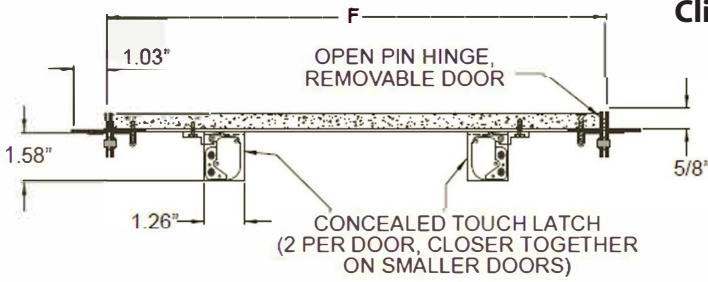

### STANDARD FEATURES

CONCEALED TOUCH LATCH; OPEN HINGE, REMOVABLE DOOR; SUPPLIED TO FIT 5/8" DRYWALL; DESIGNED FOR NON-RATED WALLS & CEILINGS; ALUMINUM FRAME AND DOOR STRUCTURE, WELDED MILL FINISH; NON-SNAG REMOVABLE SAFETY CABLE

### DOOR PANEL OPTION

- MOISTURE RESISTANT PURPLE (GREEN) BOARD PRE-INSTALLED (STANDARD)
- DOOR AND FRAME STRUCTURE ONLY
- 

### ADDITIONAL LOCKING OPTIONS

- SQUARE CAM LATCH & TOOL KEY
- CYLINDER LOCK & KEY
- None - or enter instructions here

QTY.	NOMINAL SIZE		A		B		C		D		E		F		OPTIONS
	Inch	mm	Inch	mm	Inch	mm	Inch	mm	Inch	mm	Inch	mm	Inch	mm	
	8 x 8	203 x 203	8.00	203	8.00	203	10.20	258	10.20	258	8.14	207	8.14	207	2
	12 x 12	305 x 305	12.00	305	12.00	305	14.20	359	14.20	359	12.14	308	12.14	308	2
	16 x 16	406 x 406	16.00	406	16.00	406	18.20	461	18.20	461	16.14	410	16.14	410	2
	18 x 18	457 x 457	18.00	457	18.00	457	20.20	512	20.20	512	22.14	461	22.14	461	2
	20 x 20	508 x 508	20.00	508	20.00	508	22.20	562	22.20	562	20.14	512	20.14	512	2
	24 x 24	610 x 610	24.00	610	24.00	610	26.20	664	26.20	664	24.14	613	24.14	613	2
	24 x 36	610 x 915	24.00	610	36.00	915	26.20	664	38.20	969	24.14	613	36.14	919	2
	X	X													2

Dimensions are subject to manufacturer's tolerance of plus or minus 1/4". BestAccessDoors assumes no responsibility for use of void or suspended data. Please always make sure to use current specifications.

BestAccessDoors



Call toll free World Wide.  
 Phone: 1-800-483-0823  
 Fax: 1-888-828-6021

Email: sales@bestaccessdoors.com  
 Website: www.bestaccessdoors.com  
 P.O. Box 4668, #76520 New York, NY 10163-4668