



Quality Access Doors- FAST!

# SUBMITTAL/TECHNICAL DATA SHEET

## APPLICATION

Designed for interior and exterior applications that require an access opening that will blend in with the surrounding floor material

## FEATURES

- Recessed 1/8" to accommodate carpeting and vinyl tile.
- Door panel is equipped with a flush aluminum drop handle and an automatic hold open arm

## SPECIFICATIONS

**MATERIAL:** Aluminum door and frame

**DOOR:** 1/4" smooth aluminum plate reinforced for live load of 150 lb/sq. ft. Extruded edging is welded to door panel, providing a 1/8" recess

**FRAME:** Angle frame fabricated from aluminum extrusion with integral 1" anchor flange on three sides and welded anchor straps on the hinge side

**HINGE:** Extruded aluminum hinges are welded to inside of door panel and pivot on stainless steel pins. Hold open arm with red Vinyl grip allow automatic opening

**OPENING DEVICE:** Door panel to open to 90 degrees, locking door in open position, and allowing for easy control when closing door panel. Stainless steel torsion bars provide lift assistance. Available with electrical actuators, operated by wall mounted push button switch, and remote control

**STANDARD LATCH:** Stainless steel slamlock with a fixed inside handle, removable outside handle, and removable threaded plug

**FINISH:** Mill finish with bituminous coating applied to exterior of frame

SKU: **BA-FT-8040-DL**

# FLOOR DOOR

RECESSED 1/8" FOR VINYL TILE/CARPET

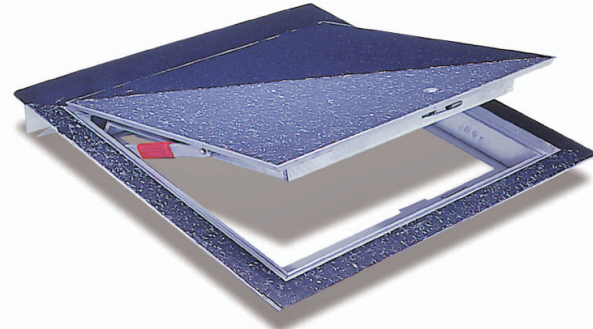

## DIMENSIONS AND APPEARANCE

>> CLICK TO VIEW ADDITIONAL DETAILS AND PRICING <<

DOOR SIZE W x H INCHES (MM)	WEIGHT	
	LBS	KG
24 x 24 (609 x 609)	25	11
24 x 30 (609 x 762)	54	24
24 x 36 (609 x 914)	62	28
30 x 30 (762 x 762)	74	33
30 x 36 (762 x 914)	82	37
36 x 36 (914 x 914)	85	38
42 x 42 (1066 x 1066)	90	40
*48 x 48 (1220 x 1220)	155	71
*48 x 72 (1220 x 1829)	220	100
*60 x 60 (1524 x 1524)	225	102

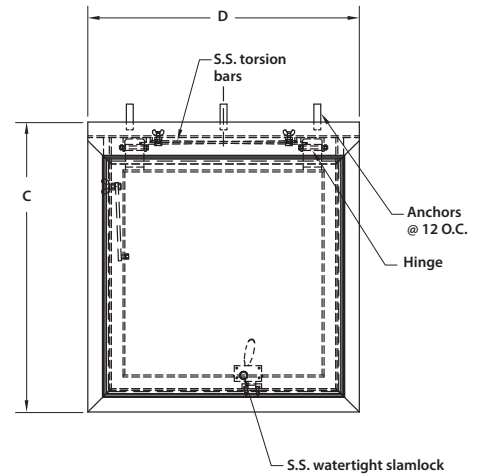

\* DOUBLE LEAF  
For detailed specifications see submittal sheet  
**MANUFACTURED BY ACUDOR**

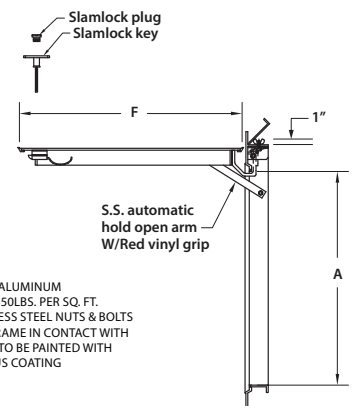
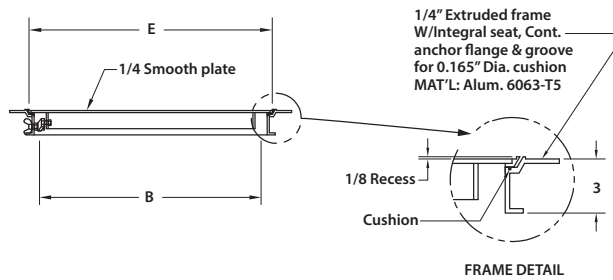

NOTES:  
 • MATERIAL: ALUMINUM  
 • LOADING: 150LBS. PER SQ. FT.  
 • 316 STAINLESS STEEL NUTS & BOLTS  
 • AREA OF FRAME IN CONTACT WITH CONCRETE TO BE PAINTED WITH BITUMINOUS COATING

For a complete list of options visit [www.BestAccessDoors.com](http://www.BestAccessDoors.com)

## PROJECT DATA

Custom Sizes Available - Fast!

PROJECT NAME :	QTY	W	H	OPTIONS
ARCHITECT :				
DEALER :				
CONTRACTOR :				
LOCATION :	SPECIAL INSTRUCTIONS :			
DATE :				
TAGGING INSTRUCTIONS :	SUBMITTAL APPROVAL : (signature or stamp)			

Scan or Click



To view Pricing and Additional Product Info.

TELEPHONE:  
1-800-483-0823  
FAX:  
1-888-828-6021

228 PARK AVE. S. #76520  
NEW YORK, NY, 10003



WEBSITE:  
[www.BestAccessDoors.com](http://www.BestAccessDoors.com)  
E-MAIL:  
[info@bestaccessdoors.com](mailto:info@bestaccessdoors.com)

**BA-FT-8040-DL**

**1/8" RECESSED FOR VINYL TILE/CARPET - SINGLE LEAF**

NOMINAL SIZE inches (mm)	CLEAR OPENING		OVERALL SIZE		RECEIVING TILE AREA		WEIGHT lbs. (kg)
	A	B	C	D	E	F	
24 x 24 (609 x 609)	22.75 (578)	22.75 (578)	31.125 (793)	28.75 (730)	24.00 (609)	24.00 (609)	25 (11)
24 x 30 (609 x 762)	22.75 (578)	28.75 (730)	31.125 (793)	34.75 (882)	30.00 (762)	24.00 (609)	54 (24)
24 x 36 (609 x 914)	22.75 (578)	34.75 (882)	31.125 (793)	40.75 (1035)	36.00 (914)	24.00 (609)	62 (28)
30 x 30 (762 x 762)	28.75 (730)	28.75 (730)	37.125 (942)	34.75 (882)	30.00 (762)	30.00 (762)	74 (33)
30 x 36 (762 x 914)	28.75 (730)	34.75 (882)	37.125 (942)	40.75 (1035)	36.00 (914)	30.00 (762)	82 (37)
36 x 36 (914 x 914)	34.75 (882)	34.75 (882)	43.125 (1092)	40.75 (1035)	36.00 (914)	36.00 (914)	85 (38)
42 x 42 (1066 x 1066)	40.75 (1035)	40.75 (1035)	49.125 (1247)	46.75 (1187)	42.00 (1066)	42.00 (1066)	90 (40)

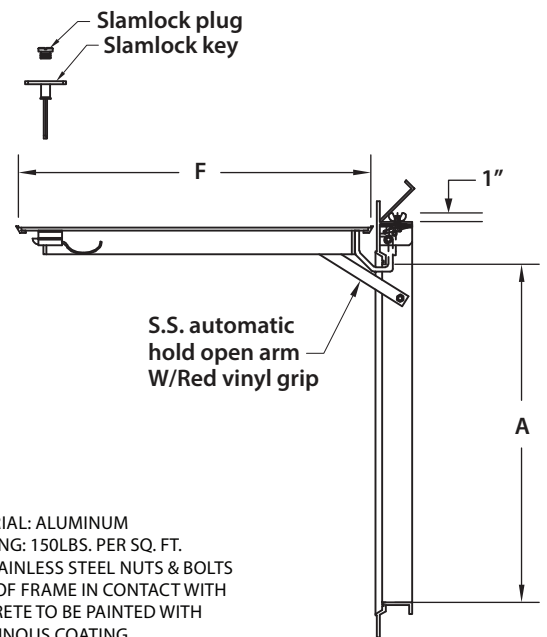
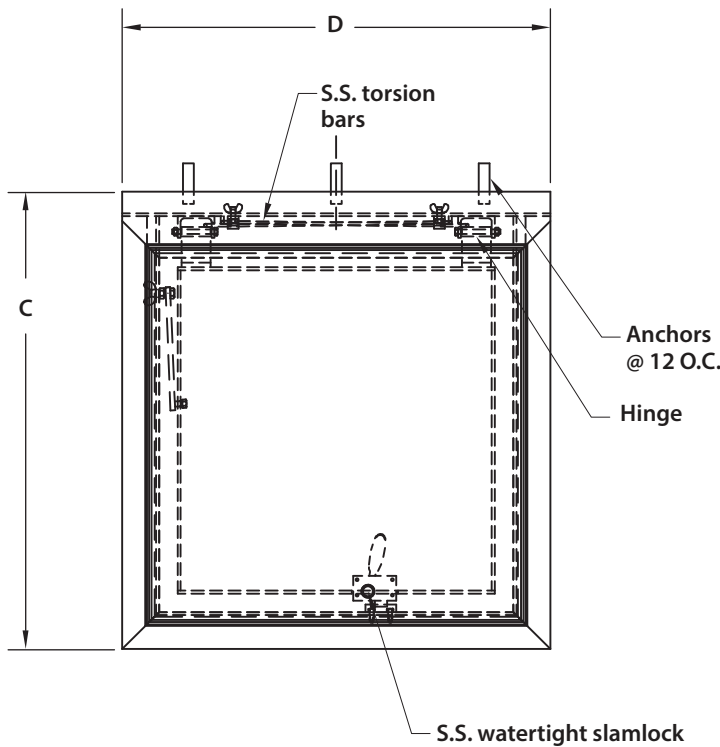

- NOTES:
- MATERIAL: ALUMINUM
  - LOADING: 150LBS. PER SQ. FT.
  - 316 STAINLESS STEEL NUTS & BOLTS
  - AREA OF FRAME IN CONTACT WITH CONCRETE TO BE PAINTED WITH BITUMINOUS COATING

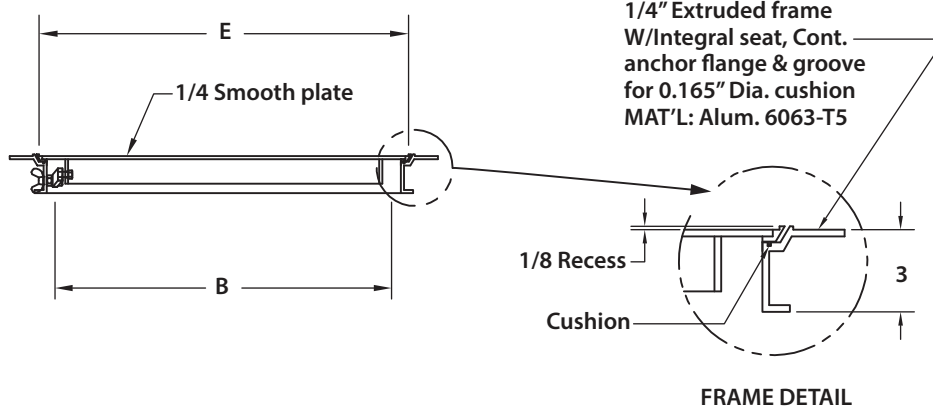

# BA-FT-8040-DL 1/8" RECESSED FOR VINYL TILE/CARPET - DOUBLE LEAF

NOMINAL SIZE inches (mm)	CLEAR OPENING		OVERALL SIZE		RECEIVING TILE AREA		WEIGHT
	A	B	C	D	E	F	lbs. (kg)
48 x 48 (1220 x 1220)	47 (1193)	46.75 (1187)	58.00 (1473)	52.75 (1339)	48.00 (1220)	24.00 (609)	155 (71)
48 x 72 (1220 x 1829)	69 (1752)	46.75 (1187)	81.50 (2070)	52.75 (1339)	48.00 (1220)	35.75 (908)	220 (100)
60 x 60 (1524 x 1524)	59 (1498)	58.75 (1492)	70.00 (1778)	64.75 (1644)	60.00 (1524)	30.00 (762)	225 (102)

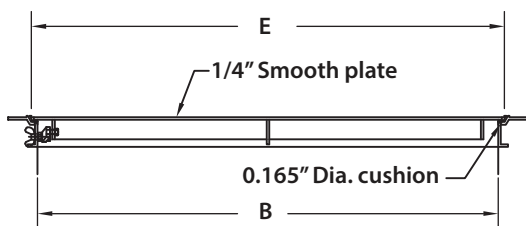
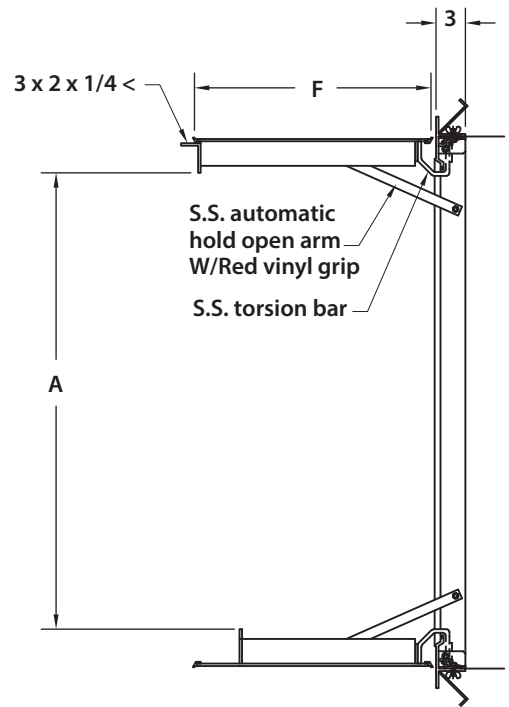
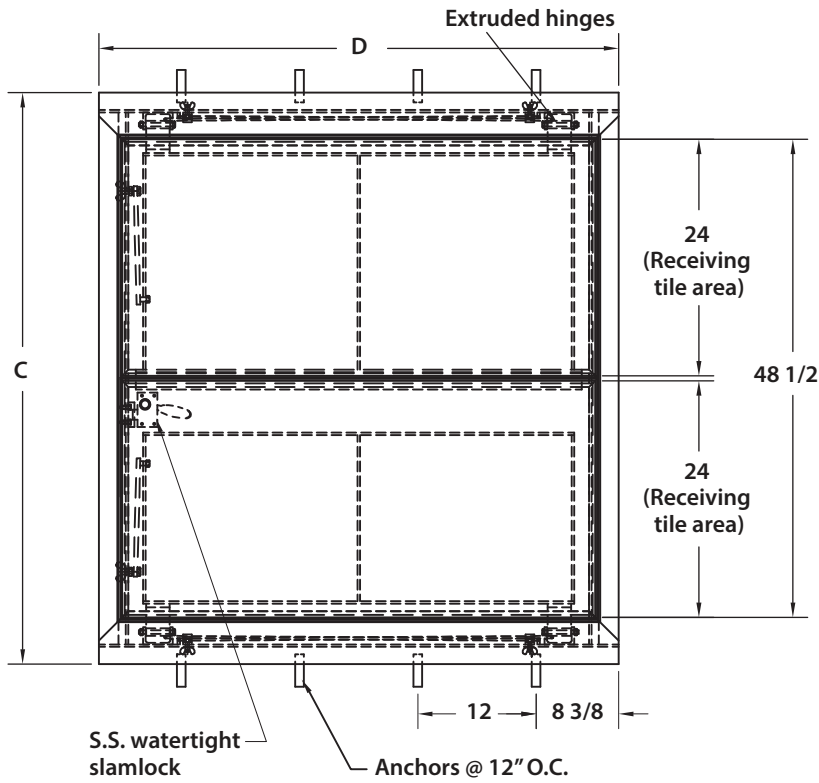

- NOTES:
- MATERIAL: ALUMINUM
  - LOADING: 150LBS. PER SQ. FT.
  - 316 STAINLESS STEEL NUTS & BOLTS
  - AREA OF FRAME IN CONTACT WITH CONCRETE TO BE PAINTED WITH BITUMINOUS COATING

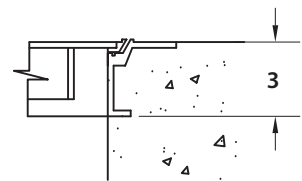

**FRAME DETAIL**