



Quality Access Doors- FAST!

SUBMITTAL/TECHNICAL DATA SHEET

SPECIFICATIONS

MATERIAL:

- GA: 1/4" Steel Tread Plate and 1/4" extruded aluminum frame
- GD: 1/4" Aluminum Tread Plate and 1/4" extruded aluminum frame

FINISH:

- GA: Grey Powder Coat
- GD: Mill Finish

COVER:

- GA: Steel Diamond patterned safety tread plate designed to support 300 psf live load.
- GD: Aluminum Diamond patterned safety tread plate designed to support 300 psf live load.

FRAME: 1/4" Extruded aluminum frame with integral masonry anchor. Frame construction contains drainage gutter around perimeter with 1-1/2" drain coupling to connect with interior drain.

LATCH:

- Single Leaf: Single Snap Latch
- Double Leaf: Two-point snap latch with throw bolt on inactive leaf.

HANDLE: Inside handle and removable outside T handle.

LIFT ASSISTANCE: Torsion Coil.

HARDWARE: Stainless steel.



SKU: **BA-GA-SL**

SINGLE LEAF SIDE WALK DOOR

DIMENSIONS AND APPEARANCE

>> [CLICK TO VIEW ADDITIONAL DETAILS AND PRICING <<](#)

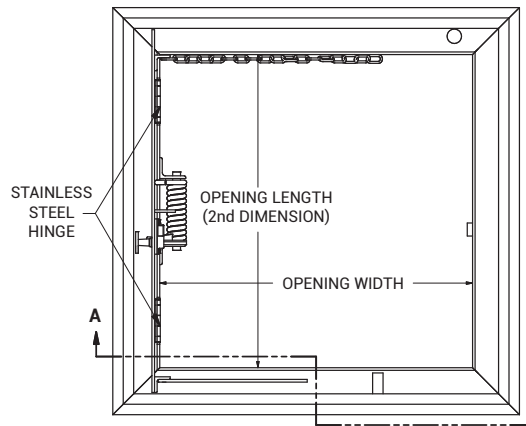

NOTES:

- 1) POWDER COATED GRAY
- 2) APPROVED BY FACTORY MUTUAL
- 3) RATED FOR: 300psf LIVE LOAD
- 4) MATERIAL:
FRAME - 1/4" EXTRUDED ALUMINUM
COVER - 1/4" STEEL TREAD PLATE
HINGES - 304 STAINLESS STEEL
HARDWARE - 304 STAINLESS STEEL W/ EXCEPTIONS

5) SIZES:

- GA-1 2'0" X 2'0"
- GA-2 2'6" X 2'6"
- GA-3 3'0" X 2'6"
- GA-4 3'0" X 3'0"

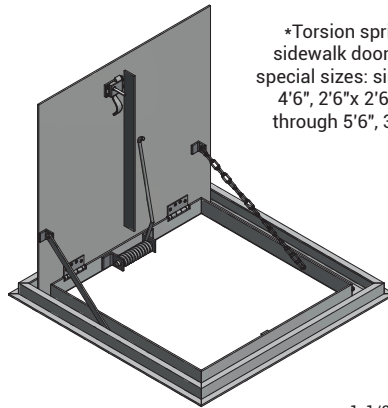

*Torsion spring not provided on aluminum sidewalk doors in the following standard and special sizes: single leaf type- 2'0" x 2'0" through 4'6", 2'6" x 2'6", double leaf type- 2'10" x 3'4" through 5'6", 3'10" x 3'10" through 4'0" x 4'0".

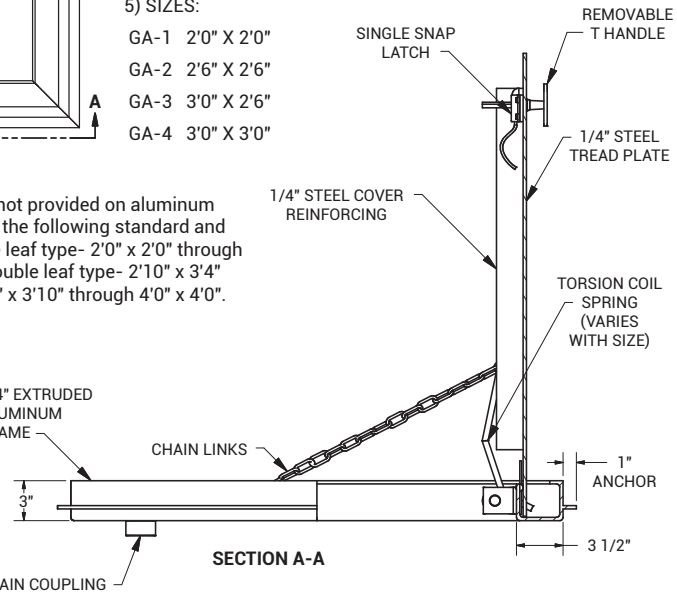

For a complete list of options visit www.BestAccessDoors.com

PROJECT DATA

Custom Sizes Available - Fast!

Scan or Click



PROJECT NAME :	QTY	W	H	OPTIONS
ARCHITECT :				
DEALER :				
CONTRACTOR :				
LOCATION :	SPECIAL INSTRUCTIONS :			
DATE :	SUBMITTAL APPROVAL : (signature or stamp)			
TAGGING INSTRUCTIONS :				

TELEPHONE:
1-800-483-0823
FAX:
1-888-828-6021



228 PARK AVE. S. #76520
NEW YORK, NY, 10003



WEBSITE:
www.BestAccessDoors.com
E-MAIL:
info@bestaccessdoors.com

To view Pricing and Additional Product Info.