



Quality Access Doors - FAST !



Duct Access Door BA-GDD Grease Duct Door

Application

- Access door for installation in Kitchen Exhaust Systems
- This door meets or exceeds requirements of all mechanical codes

Product Features

- Bolt in unit easily installed into existing ductwork
- Duct cutout template included
- No bolts penetrate to the interior of the duct
- Two handles for easy removal and installation
- 16 Gage galvanized steel
- N.F.P.A. #96

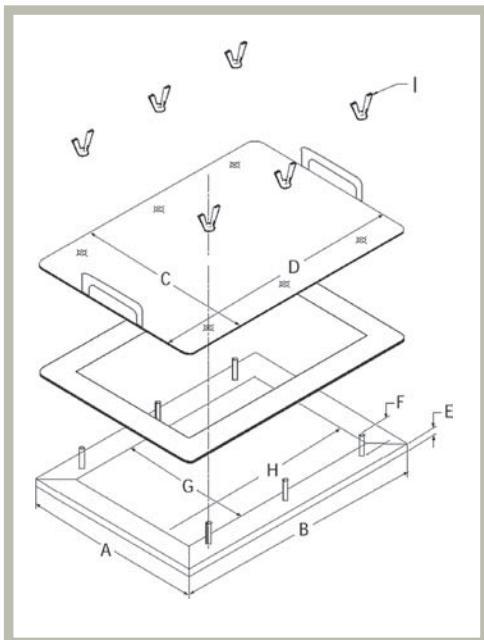

AVAILABLE SIZES *(Special sizes available upon request)*

Order Size	A	B	C	D	E	F	G	H	I (QTY)
7" x 7"	10"	10"	10.5"	10.5"	.5"	1"	7"	7"	4
7" x 12"	10"	15"	10.5"	10.5"	.5"	1"	7"	12"	6
7" x 20"	10"	23"	10.5"	23.5"	.5"	1"	7"	20"	10
12" x 12"	15"	15"	15.5"	15.5"	.5"	1"	12"	12"	8
12" x 20"	15"	23"	15.5"	23.5"	.5"	1"	12"	20"	12
16" x 20"	19"	23"	19.5"	23.5"	.5"	1"	16"	20"	12
20" x 20"	23"	23"	23.5"	23.5"	.5"	1"	20"	20"	16

For detailed specifications see submittal sheet

[Click here to view the Products](#)