



Quality Access Doors- FAST!

SUBMITTAL/TECHNICAL DATA SHEET

SKU: **BA-HHD-GYP-110**

HEAVY DUTY ACCESS DOOR FOR LARGE OPENINGS

WITH DRYWALL BEAD FLANGE

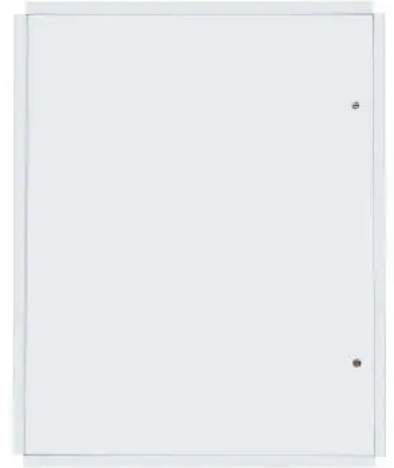

STANDARD OPTIONS

- MATERIAL:**
16 gauge cold rolled steel
- HINGE:**
Continuous piano hinge
- LOCK / LATCH:**
Screwdriver-operated cylinder cam latch
- FINISH:**
High quality white powder coat primer
- PACKAGING:**
• Individually wrapped
• 1 Per box

INSTALLATION

>> [CLICK TO VIEW ADDITIONAL DETAILS AND PRICING <<](#)

OPTIONS AVAILABLE

- MATERIAL:**
Stainless steel 304 #4 (brushed finish)
- LOCK / LATCH:**
- Key operated cylinder cam latch
 - Handle operated cam latch
 - Mortise preparation for cylinder (cylinder optional)
 - Mortise deadbolt lock
- DESIGN:** Double leaf

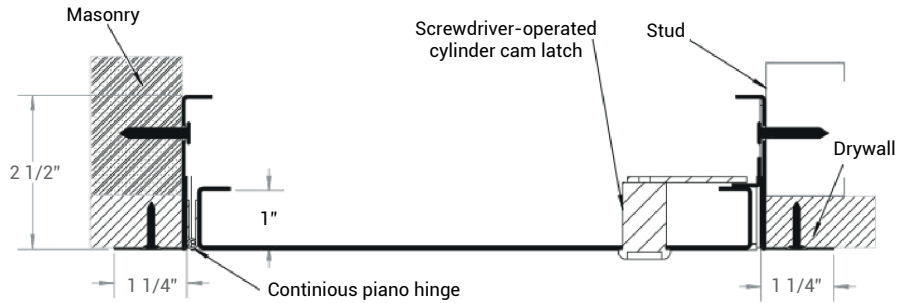

DIMENSIONS AND APPEARANCE

For a complete list of options visit www.BestAccessDoors.com

STANDARD SIZES:

DOOR SIZE W x H INCHES (MM)	NUMBER OF LOCKS	WEIGHT LBS	KG
48 x 48 (1219 x 1219)	2	61.1	27.7

Rough wall opening = door size + 1/4" or + 6mm

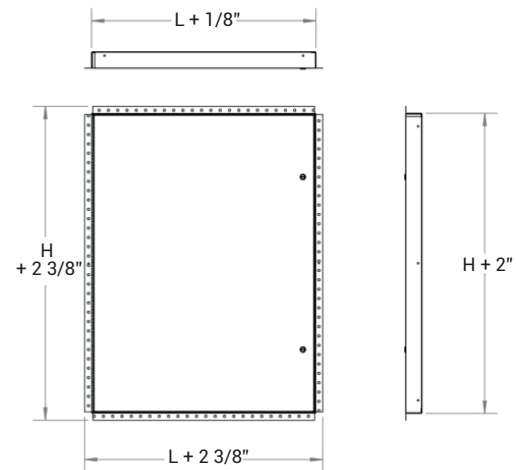

Scan or Click



To view Pricing and Additional Product Info.

LEED READY: THIS PRODUCT CONTRIBUTES TO LEED® CREDITS

PROJECT DATA

Custom Sizes Available - Fast!

PROJECT NAME :	QTY	W	H	OPTIONS
ARCHITECT :				
DEALER :				
CONTRACTOR :				
LOCATION :	SPECIAL INSTRUCTIONS :			
DATE :				
TAGGING INSTRUCTIONS :	SUBMITTAL APPROVAL : (signature or stamp)			



TELEPHONE:
1-800-483-0823

FAX:
1-888-828-6021



228 PARK AVE. S. #76520
NEW YORK, NY, 10003



WEBSITE:
www.BestAccessDoors.com

E-MAIL:
info@bestaccessdoors.com