

Aluminum panel for masonry applications

Aluminum frame, with drywall inlay, for masonry applications **SYSTEM BA-MW**

Alu
for masonry
applications

Description

The access panel consists of a welded aluminum frame and is available with or without 1/2" (12.7 mm) or 5/8" (15.9 mm) inlayed drywall and two latches.

Both an outer and an inner frame assembly consists of high grade aluminum which is bonded with a special welding process.

For sizes 12" x 12" (305 x 305 mm) and up the access panels are equipped with a safety system to prevent accidental opening. This safety system must be reattached if the hatch is removed.

The reveal of 1/16 of an inch (1.59 mm) is visible between the outer frame and door hatch. The concealed snap locks open the access panel when pressure is applied to the spring loaded latch side.

This access panel is designed to be recessed into concrete wall systems. This panel comes with predrilled holes for easy installation.

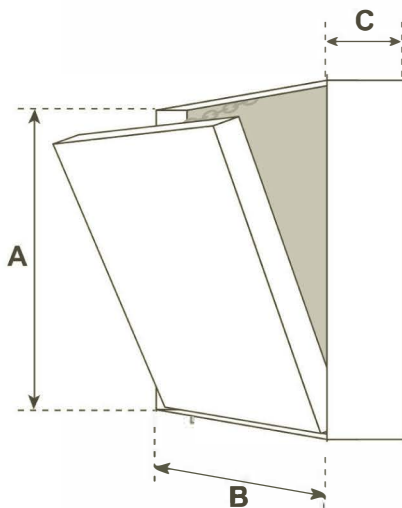

Customized solutions

Customized sizes can be produced in every dimension upon request.

Locks

The access panel can be equipped with the following types of locks:

- Four-square lock
- Round-cylinder lock



Best Access Doors

[Click here to view the Products](#)

Advantages of BestAccessDoors Panels

- Superior engineering & innovative design
- Fast delivery
- Quick and easy installation
- Solid aluminum frame
- Flush installation in ceilings and walls
- Available in moisture resistant, mildew resistant and cement board

