



Quality Access Doors - FAST!

SUBMITTAL/TECHNICAL DATA SHEET

SKU: BA-PDCM

ALUM. PRECAST VAULT DRAINAGE FLOOR DOOR



SPECIFICATIONS

01. Heavy duty forged brass hinges with stainless steel pins
02. Guide arm (If req'd)
03. 1-1/2" drain coupling
04. Standard slam lock
05. Cam assembly
06. Automatic hold open arm w/ red vinyl grip
07. 1/4" Aluminum diamond pattern plate cover
08. 1/4" Aluminum channel frame with extruded anchor flange
09. Stainless steel lock strike
10. Torsion rods (stainless steel)

SHOP FINISH:

ALUMINUM: Mill finish
 HARDWARE: Zinc plated & chromate sealed (Unless otherwise specified)

Reinforced for 300 Lbs. Per Sq. Ft. (1464 KG. Per Sq. Meter) live load

INSTALLER NOTES:

A. Use caution. Cover is spring loaded. Do not remove safety shipping bolt until unit is to be installed and in normal horizontal operating position.

B. Be sure unit is set on slight pitch toward drain corner.

C. Before anchoring in place open and close door. Check to see that the door in the closed position rests on the frame all around. If not, shim under the frame at the proper corner.

D. Do not reduce 1 1/2" drain pipe to dry well or disposal system.

For a complete list of options visit www.BestAccessDoors.com

DIMENSIONS AND APPEARANCE

>> CLICK TO VIEW ADDITIONAL DETAILS AND PRICING <<

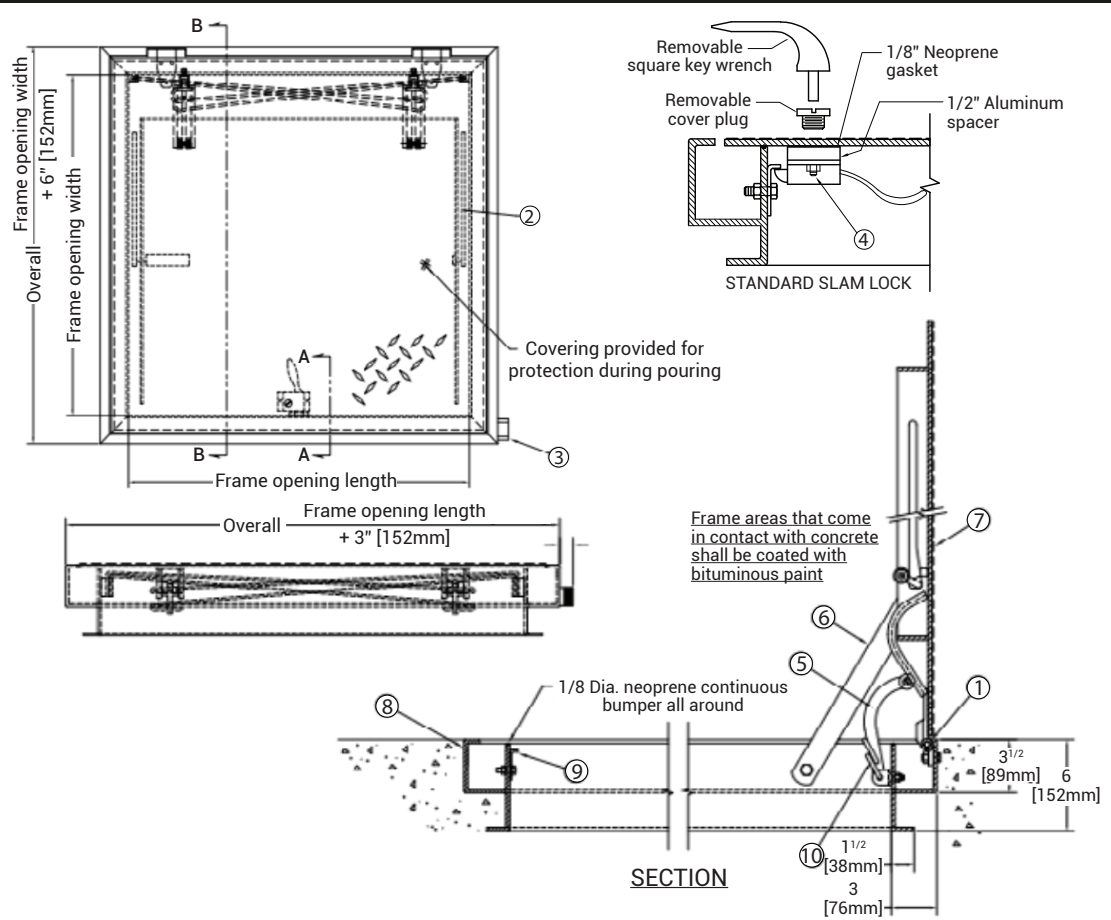

PROJECT DATA

Custom Sizes Available - Fast!

Scan or Click



BEST ACCESS DOORS

To view Pricing and Additional Product Info.

PROJECT NAME :	QTY	W	H	OPTIONS
ARCHITECT :				
DEALER :				
CONTRACTOR :				
LOCATION :	SPECIAL INSTRUCTIONS :			
DATE :				
TAGGING INSTRUCTIONS :	SUBMITTAL APPROVAL : (signature or stamp)			

TELEPHONE:
1-800-483-0823
FAX:
1-888-828-6021



228 PARK AVE. S. #76520
NEW YORK, NY, 10003



WEBSITE:
www.BestAccessDoors.com
E-MAIL:
info@bestaccessdoors.com