



Quality Access Doors- FAST!

SUBMITTAL/TECHNICAL DATA SHEET

SPECIFICATIONS

- 01. Frame with capflashing (Corners full welded)
 - S-20 - 14 gauge P.B. Galv. steel
 - S-40 - 14 gauge P.B. Galv. steel
 - S-50 - 11 gauge aluminum
 - S-90 - 14 gauge type 304 stainless steel
- 02. Pintle hinge
- 03. Gasket (All around cover)
- 04. Cover gauge
 - S-20 - 14 gauge P.B. Galv. steel
 - S-40 - 11 gauge aluminum
 - S-50 - 11 gauge aluminum
 - S-90 - 14 gauge type 304 stainless steel
- 5. Cover liner
 - S-20 - 22 gauge P.B. Galv. steel
 - S-40 - 18 gauge aluminum
 - S-50 - 18 gauge aluminum
 - S-90 - 22 gauge type 304 stainless steel
- 06. Spring lifting mechanism
- 07. 1" rigid fiberboard insulation
- 08. Slam latch
- 09. Inside and outside handles with padlock hasps
- 10. Arm guide bracket
- 11. 1" thick fiberglass cover insulation
- 12. Hold open arm with Red vinyl grip
- 13. Neoprene gasket
- 14. Lock strike & padlock hasp
- 15. Bilclip® flashing system

SHOP FINISH:

- STEEL: Red oxide primer
- ALUMINUM: Mill finish
- HARDWARE: Non-corrosive materials (Unless otherwise specified)
- STAINLESS STEEL: Beadblast finish type 316 s/s hardware

This product may be installed on either a flat or sloping roof. When installed on a slope, the hinge side must run parallel with the slope. If slope exceeds 30°, advise factory for modification.

For a complete list of options visit www.BestAccessDoors.com

QTY	TYPE	METAL
<input type="checkbox"/>	S-20	Steel cover/Steel frame
<input type="checkbox"/>	S-40	Alum. Cover/Steel frame
<input type="checkbox"/>	S-50	Alum. Cover/Alum. Frame
<input type="checkbox"/>	S-90	Stls. stl. cover/Stls. stl. frame

TYPE E SIZE 3'-0" X 2'-6" (WIDTH X HEIGHT)

SKU: BA-S-40

SINGLE LEAF ROOF SCUTLE



DIMENSIONS AND APPEARANCE

>> CLICK TO VIEW ADDITIONAL DETAILS AND PRICING <<

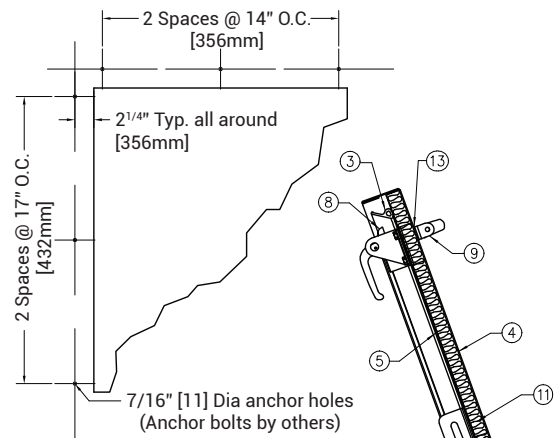
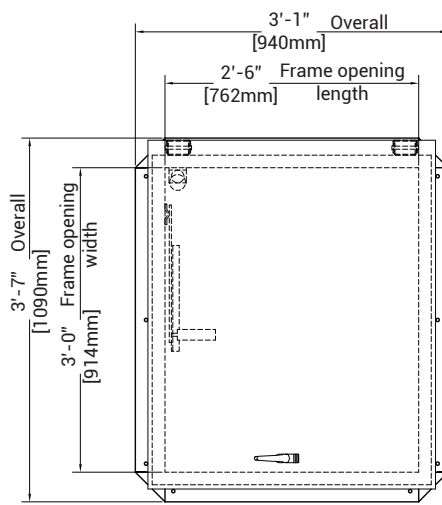

ANCHOR HOLE LAYOUT

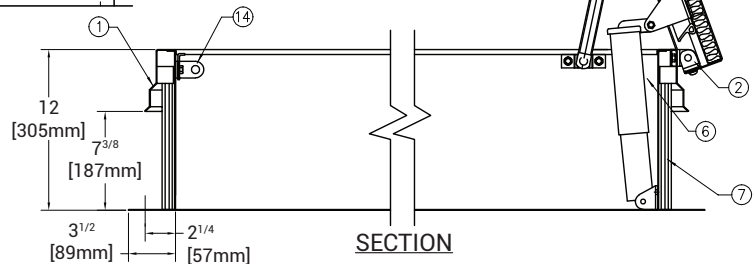
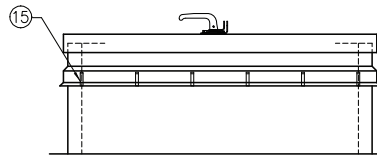

SECTION

MIAMI-DADE PRODUCT APPROVED (NOA NO. 19-1029.10) MEETING LARGE AND SMALL MISSILE IMPACT REQUIREMENTS FLORIDA PRODUCT APPROVAL #FL15110

TYPE: S-20 AND S-50 ONLY

PROJECT DATA

Custom Sizes Available - Fast!

Scan or Click



To view Pricing and Additional Product Info.

PROJECT NAME :	QTY	W	H	OPTIONS
ARCHITECT :				
DEALER :				
CONTRACTOR :				
LOCATION :	SPECIAL INSTRUCTIONS :			
DATE :				
TAGGING INSTRUCTIONS :	SUBMITTAL APPROVAL : (signature or stamp)			

TELEPHONE:
1-800-483-0823
FAX:
1-888-828-6021



228 PARK AVE. S. #76520
NEW YORK, NY, 10003



WEBSITE:
www.BestAccessDoors.com
E-MAIL:
info@bestaccessdoors.com