



Quality Access Doors- FAST!

SUBMITTAL/TECHNICAL DATA SHEET

STANDARD OPTIONS

- MATERIAL:**
16 gauge cold rolled steel
- HINGE:**
Continuous piano type hinge
- GASKETING:**
Neoprene gasket
- LOCK / LATCH:**
Screwdriver operated cam latch
- FINISH:**
High quality white powder coat primer
- PACKAGING:**
Individually wrapped, 1 per box

OPTIONS AVAILABLE

- LOCK / LATCH:**
- Key operated cylinder cam latch
 - Hex head cam latch
 - Pinned hex head cam latch
 - Handle operated cam latch
 - Mortise preparation for cylinder
- MATERIAL:**
Stainless steel 304 #4 (brushed finish)

For a complete list of options visit www.BestAccessDoors.com

Scan or Click



To view Pricing and Additional Product Info.

LEED READY: THIS PRODUCT CONTRIBUTES TO LEED® CREDITS



SKU: **BA-UAP-G**
GENERAL PURPOSE ACCESS DOOR WITH NEOPRENE GASKET
 FOR ALL SURFACE TYPES



INSTALLATION

>> [CLICK TO VIEW ADDITIONAL DETAILS AND PRICING <<](#)

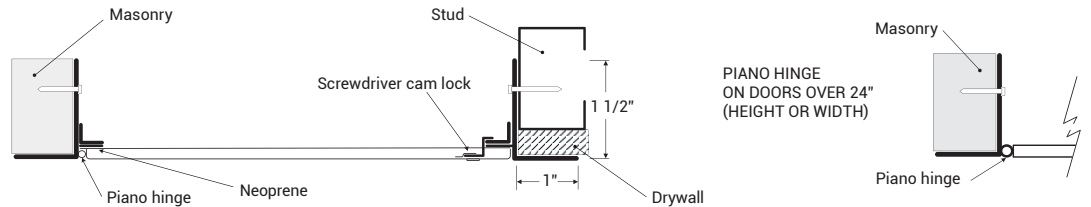

DIMENSIONS AND APPEARANCE

DOOR SIZE W x H INCHES (MM)	NUMBER OF LOCKS	WEIGHT LBS	KG
6 x 6 (152 x 152)	1	2	0.9
8 x 8 (203 x 203)	1	3	1.4
8 x 12 (203 x 304)	1	4	1.8
10 x 10 (254 x 254)	1	4	1.8
12 x 12 (304 x 304)	1	5	2.3
12 x 16 (304 x 406)	1	6.2	2.8
12 x 18 (304 x 457)	1	7	3.2
12 x 24 (304 x 609)	1	8	3.6
14 x 14 (356 x 356)	1	7	3.2
16 x 16 (406 x 406)	1	8	3.6
18 x 18 (457 x 457)	1	9	4.1
18 x 24 (457 x 609)	1	13	5.9
20 x 20 (508 x 508)	1	11	5
22 x 22 (558 x 558)	1	13	5.9
* 22 x 30 (558 x 762)	2	17	7.7
* 22 x 36 (558 x 914)	2	19	8.6
* 24 x 24 (609 x 609)	1	15	6.8
* 24 x 30 (609 x 762)	2	20	9.1
* 24 x 36 (609 x 914)	2	22	10
* 24 x 48 (609 x 1219)	2	28	12.7
* 30 x 30 (762 x 762)	4	23	12.7
* 36 x 36 (914 x 914)	4	31	14.1

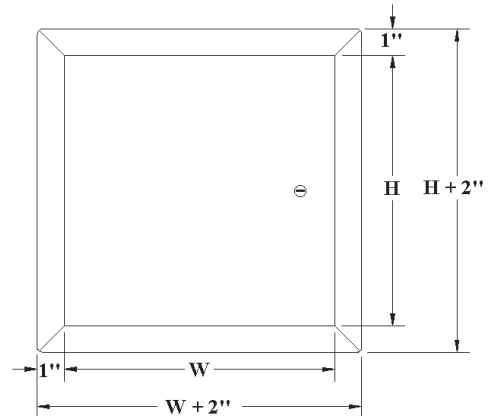

ROUGH WALL OPENING IS DOOR SIZE + 1/4" OR + 6MM
 * Piano hinge on doors over 24 inches (height or width)
 The BA-LHD model is recommended for over 1296 sq. inches

PROJECT DATA

Custom Sizes Available - Fast!

PROJECT NAME :	QTY	W	H	OPTIONS
ARCHITECT :				
DEALER :				
CONTRACTOR :				
LOCATION :	SPECIAL INSTRUCTIONS :			
DATE :				
TAGGING INSTRUCTIONS :	SUBMITTAL APPROVAL : (signature or stamp)			

TELEPHONE:
1-800-483-0823

FAX:
1-888-828-6021

228 PARK AVE. S. #76520
NEW YORK, NY, 10003

WEBSITE:
www.BestAccessDoors.com

E-MAIL:
info@bestaccessdoors.com