

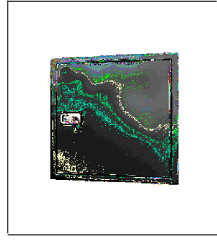

**Best Access Doors**

**ACOUSTICAL ACCESS DOOR**  
**Model BA-KRP-STC (STC 64)**  
**For All Types of Construction**



**BestAccessDoors**  
 Phone: 1-800-483-0823  
 Fax: 1-888-828-6021  
 427 N Tatnail St, #76520  
 Wilmington, DE 19801-2230  
 www.bestaccessdoors.com

[Click here to view the Products](#)

DATE

**SPECIFICATIONS**

**GENERAL SCOPE:**

Access doors shall be BestAccessDoor's BA-STC

**CONSTRUCTION:**

1. Frame shall be 16 gauge steel.
2. Door shall be 20 gauge steel.
3. Trim shall be 1" wide, one piece construction.
4. Gasketing between door and frame 3/8" wide by 1/8" thick closed cell neoprene gasketing.
5. Acoustical insulation shall be 2 3/8" thick.
6. Hinge shall be continuous piano hinge.
7. Latches shall be Lift & Turn Compression Latch finished in chrome with cup sealing gasket finished in chrome, keyed.
8. Finish shall be prime coat of rust inhibitive electrostatic powder, baked white enamel. Stainless steel shall have No. 4 finish.
9. **Independently tested in accordance with ASTM: E1332, ASTM: E90, and ASTM: E413, and rated of STC 64 when installed according to manufacture's instruction.**

**STANDARD SIZES (Special sizes on request)**

DOOR SIZE H X W (IN.)	WALL/CEILING OPENING (IN.)	NUMBER OF STUD LATCHES	SHIP WT. (LBS.)
12 x 12	12 3/8 x 12 3/8	1	6.3
18 x 18	18 3/8 x 18 3/8	1	10.5
24 x 24	24 3/8 x 24 3/8	2	16.0

\*Available in stainless steel

PROJECT DATA					
Project Name:					
Architect:					
Contractor:					
Agent/Customer Name:					
Tagging Instructions:					
Special Instructions:					

PROJECT SCHEDULE					
Qty.	H	W	No. of Latches	Finish	Remarks

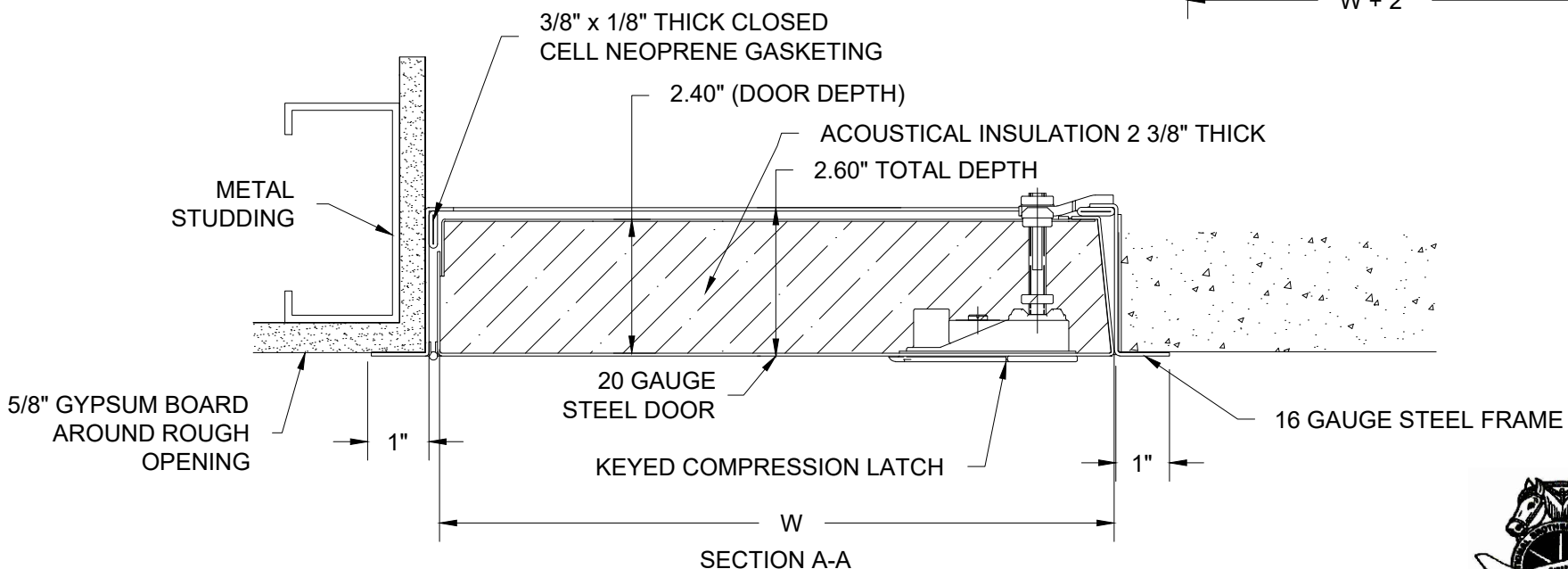
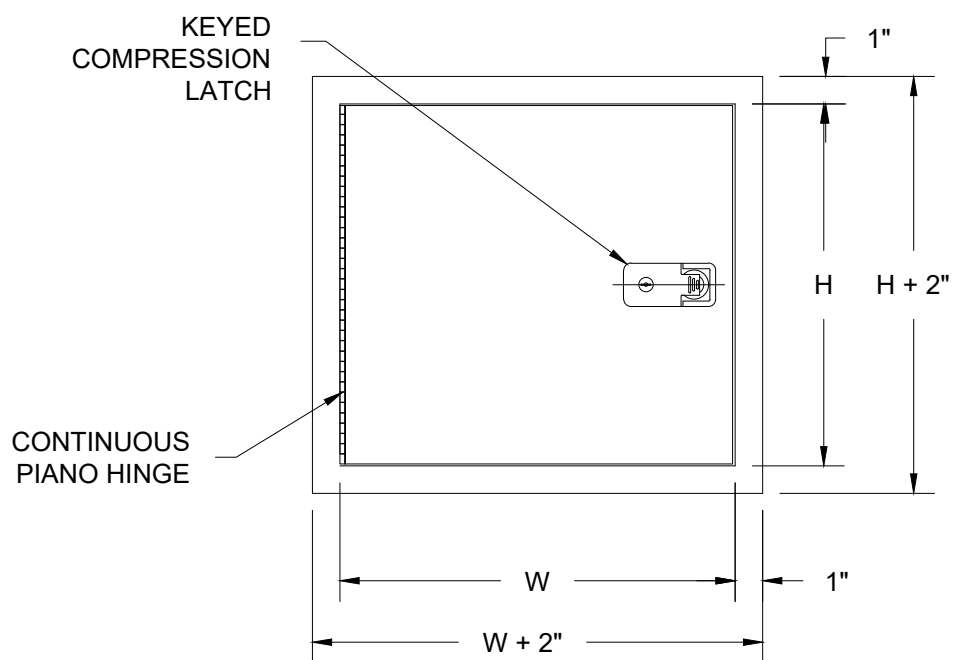

**Made with Union Labor**